



*MATERIALS TECHNOLOGY - WOOD
STUDENT WORKBOOK
PART 2*

by Sean Geasley

Junior Certificate School Programme

Materials Technology Wood

Student Workbook Part 2

Sean Geasley

Published in 2007

Junior Certificate School Programme Support Service
Curriculum Development Unit
Sundrive Road
Crumlin
Dublin 12

Phone: 01 453 5487

Fax: 01 402 0435

Email: jcsp@iol.ie

© Junior Certificate School Programme Support Service

MTW Student Workbook Part 2 has been developed by Mr. Sean Geasley, Nagle Community College, Mahon, Cork.

MTW Student Workbook Part 2 has been developed to extend and complement the existing MTW Student Workbook Part 1. Workbook 2 uses the same approach and layout as the original publication. Two new MTW statements (Theory 2 and Theory 3) have been developed to correspond with this additional theory material.

The Junior Certificate School Programme Support Service is funded by the Teacher Education Section, Department of Education and Science and the European Social Fund.

The Junior Certificate School Programme is a National Programme sponsored by the Department of Education and Science and the National Council for Curriculum and Assessment.

Written by: Sean Geasley
Project Co-ordinators: Jerry McCarthy and Mary Clare Higgins
Layout Design: Melt Design Ltd | www.melt.ie



Theory 2

MTW

Statement Code no: 6

Student:

Class:

At Junior Certificate level the student can:

Demonstrate knowledge of additional theory material

Date Commenced: / /

Date Awarded: / /

Learning Targets - This has been demonstrated by your ability to:

- | | | | | |
|----|--|--------------------------|--------------------------|--------------------------|
| 1 | Describe how "air" and "kiln" seasoning work | <input type="checkbox"/> | <input type="checkbox"/> | <input type="checkbox"/> |
| 2 | List two advantages and two disadvantages of "air" and "kiln" seasoning | <input type="checkbox"/> | <input type="checkbox"/> | <input type="checkbox"/> |
| 3 | Explain "moisture content" and show how to measure the moisture content of a sample of wood | <input type="checkbox"/> | <input type="checkbox"/> | <input type="checkbox"/> |
| 4 | Identify the various components of a computer desk system | <input type="checkbox"/> | <input type="checkbox"/> | <input type="checkbox"/> |
| 5 | Identify computer components as Hardware, Software, Input or Output devices | <input type="checkbox"/> | <input type="checkbox"/> | <input type="checkbox"/> |
| 6 | List three adhesives, describe what each is used for and give a method of application for each | <input type="checkbox"/> | <input type="checkbox"/> | <input type="checkbox"/> |
| 7 | Identify three methods of converting timber from a log into planks | <input type="checkbox"/> | <input type="checkbox"/> | <input type="checkbox"/> |
| 8 | Describe one advantage and one disadvantage of each method of conversion | <input type="checkbox"/> | <input type="checkbox"/> | <input type="checkbox"/> |
| 9 | List the steps involved in inserting a motif into a veneer | <input type="checkbox"/> | <input type="checkbox"/> | <input type="checkbox"/> |
| 10 | Describe the processes of Marquetry, Parquetry and Inlaying | <input type="checkbox"/> | <input type="checkbox"/> | <input type="checkbox"/> |

Refer also to: English, Art, Maths, Materials Technology: Metal, Technical Graphics, Science

Work begun | Work in progress | Work completed

Theory 3

MTW

Statement Code no: 7

Student:

Class:

At Junior Certificate level the student can:

Demonstrate further knowledge and understanding of theory material

Date Commenced: / /

Date Awarded: / /

Learning Targets - This has been demonstrated by your ability to:

- | | | | | |
|----|---|--------------------------|--------------------------|--------------------------|
| 1 | Identify the parts and colour code of a plug | <input type="checkbox"/> | <input type="checkbox"/> | <input type="checkbox"/> |
| 2 | Identify the parts of a Lathe | <input type="checkbox"/> | <input type="checkbox"/> | <input type="checkbox"/> |
| 3 | List safety rules to be followed when using the Lathe | <input type="checkbox"/> | <input type="checkbox"/> | <input type="checkbox"/> |
| 4 | Describe the steps involved in preparing a piece of wood for "between centres turning" | <input type="checkbox"/> | <input type="checkbox"/> | <input type="checkbox"/> |
| 5 | Describe the processes involved in bending and drilling acrylic | <input type="checkbox"/> | <input type="checkbox"/> | <input type="checkbox"/> |
| 6 | Separate a list of metals into ferrous and non-ferrous | <input type="checkbox"/> | <input type="checkbox"/> | <input type="checkbox"/> |
| 7 | List the steps involved in painting a ferrous metal | <input type="checkbox"/> | <input type="checkbox"/> | <input type="checkbox"/> |
| 8 | Describe the steps involved in transferring a design to a piece of wood for carving | <input type="checkbox"/> | <input type="checkbox"/> | <input type="checkbox"/> |
| 9 | List three types of carving and briefly describe the steps involved in one of these methods | <input type="checkbox"/> | <input type="checkbox"/> | <input type="checkbox"/> |
| 10 | Identify the various tools involved in carving | <input type="checkbox"/> | <input type="checkbox"/> | <input type="checkbox"/> |

Refer also to: English, Art, Maths, Materials Technology: Metal, Technical Graphics, Science

Work begun | Work in progress | Work completed

Contents

MTW Statement Code no: 6 Theory 2

Targets 1, 2 & 3:	Seasoning of Timber	1
Targets 4 & 5:	Computers & C.A.D.	13
Targets 6:	Adhesives	19
Targets 7 & 8:	Conversion of Timber	29
Targets 9 & 10:	Veneering, Marquetry, Parquetry & Inlaying	39

MTW Statement Code no: 7 Theory 3

Target 1:	Inside a Plug	51
Targets 2, 3 & 4:	Woodturning	55
Targets 5, 6 & 7:	Plastics & Metals	69
Targets 8, 9 & 10:	Woodcarving	83

MTW Statement Code no: 6 Theory 2

Targets 1, 2 & 3

Seasoning of Timber

Keywords

Moisture

Green Timber

Seasoning

Natural/Air

Kiln

Stacking

Stickers

The timber in newly felled trees is called **GREEN TIMBER**.

Green timber contains a lot of water called **MOISTURE**.

The amount of moisture in timber is known as the **MOISTURE CONTENT**.

Lowering this moisture content is called **SEASONING**.

Seasoning must lower the amount of moisture in timber to below **20%**.

Some reasons for seasoning timber are to:

- 1 Make it lighter, harder and stronger.
- 2 Make it easier to work on, with tools and machines.
- 3 Stop it being attacked by insects and fungi.
- 4 Stop it from splitting.

Two ways of seasoning are:

- 1 Natural/Air Seasoning
- 2 Kiln Seasoning

Timber is stacked for seasoning in the following way:

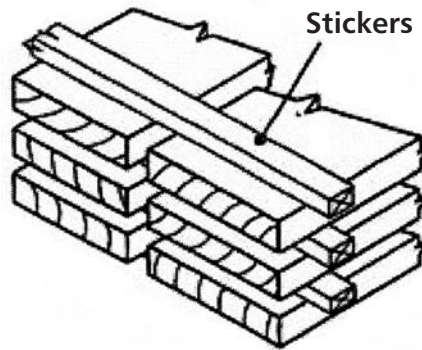

The pieces of timber called **STICKERS** separate the planks and allow air to circulate all round the timber and help drying.

1 Natural/Air Seasoning

The **STACK** of timber is covered as in the diagram to protect it from rain. It is raised off the ground using concrete blocks or bricks to stop damp rising to the timber.

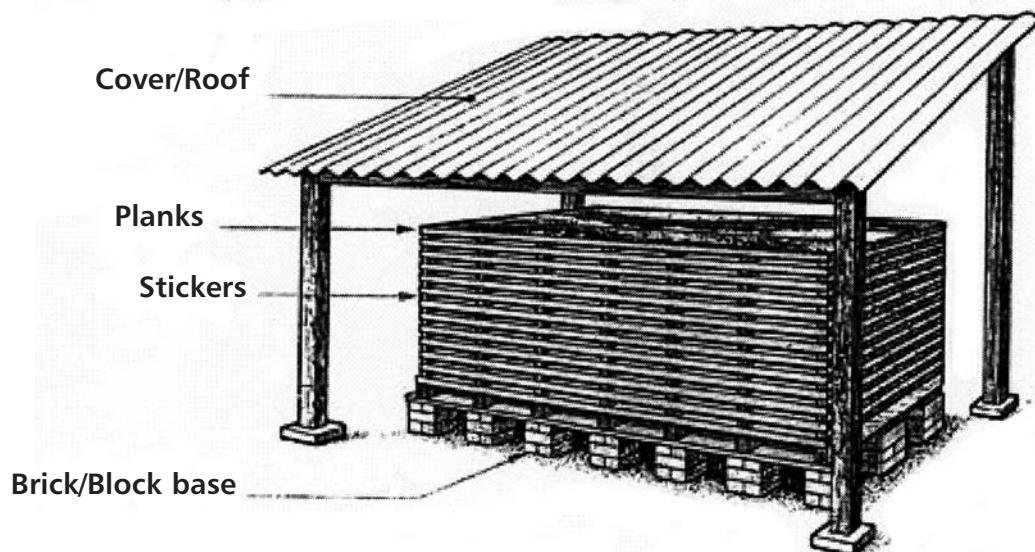

The following are ways to stop moisture from leaving the ends of the planks too quickly and causing **END-SPLITTING**.

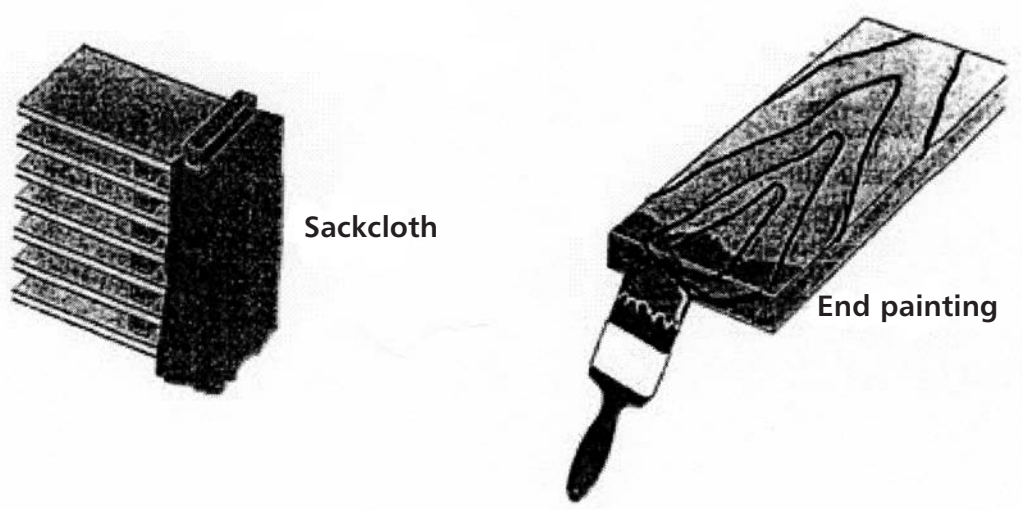

Advantages of air seasoning:

- Cheap.
- No energy wasted.
- Only work involved is building the stack.

Disadvantages of air seasoning:

- Very slow drying.
- Dependent on weather conditions.
- Can only reach a moisture content of about 20%.

Kiln Seasoning

A kiln is a large sealed box where the temperature is controlled. The stack is rolled into the kiln on a trolley.

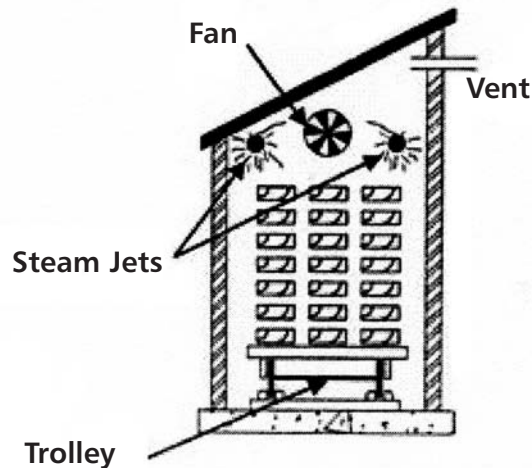

How drying takes place in a kiln:

- Hot air is used to heat the timber through to the centre.
- Fans blow steam around the stack to stop it drying too quickly.
- The vents allow wet air out and fresh air in.
- The fresh air absorbs the moisture, drying out the timber.

Advantages of kiln seasoning:

- Very quick drying.
- Can get a moisture content low enough to use timber indoors (8-10%).
- Little chance of defects caused by seasoning.

Disadvantages of kiln seasoning:

- Expensive.
- Lot of work needed.
- Dependent on energy.

Measuring moisture content of timber:

Method 1: The Oven Method

The timber is weighed, then dried out fully in an oven. The weight that's lost is the amount of moisture that was in the timber.

Method 2: Moisture Meter

The prongs shown are pushed into the wood and an instant reading is given on the meter.

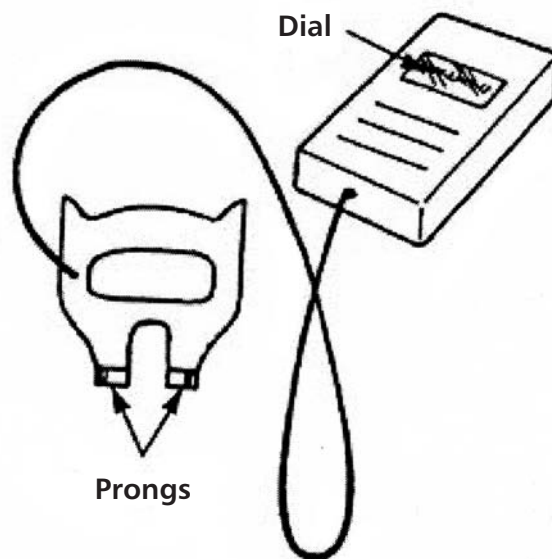

Questions on Seasoning of Timber

1 What is meant by the term green timber?

2 What do the letters M.C. stand for?

M _____ C _____

3 Explain what moisture content means.

4 What does the term seasoning mean?

5 Seasoning is needed to reduce the moisture content to below _____ %.

6 List the reasons for seasoning.

Targets 1, 2 & 3

Seasoning of Timber

7 Name 2 types of seasoning.

(i) A _____

(ii) K _____

8 In the box, draw a diagram of how timber is stacked for seasoning.

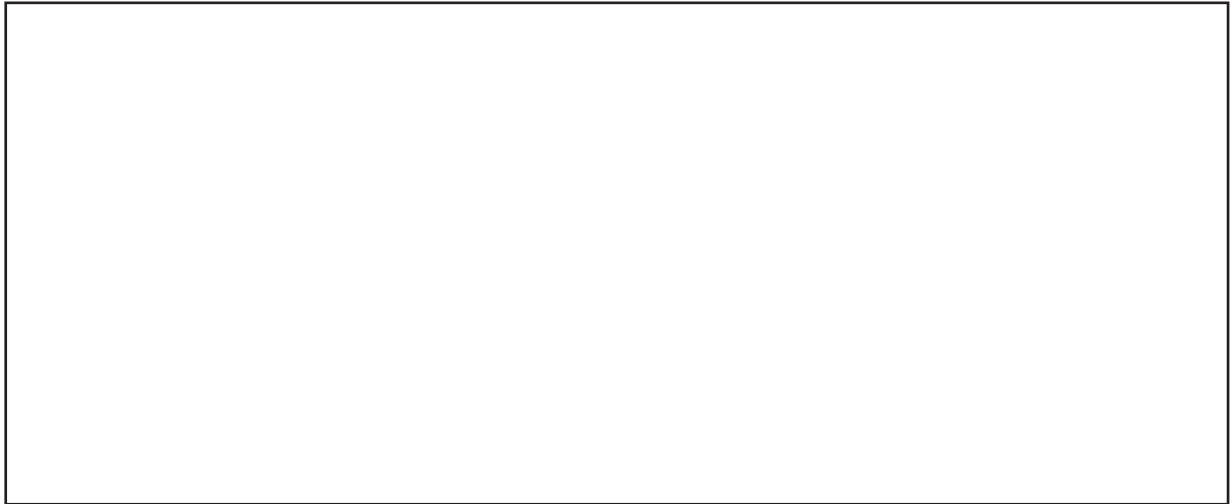

9 What is the purpose of pieces of timber called stickers in the stacking of timber?

10 List the advantages of air/natural seasoning.

11 List the disadvantages of air/natural seasoning.

12 Describe a kiln.

13 Put these words into sentences to describe how a kiln dries timber: hot air; fans; steam; rapid drying; vents; wet air; fresh air.

14 List the advantages of kiln seasoning.

15 List the disadvantages of kiln seasoning.

16 Name 2 methods of finding the moisture content of timber and describe one of them.

(i) _____ (ii) _____

Description:

Seasoning Crossword

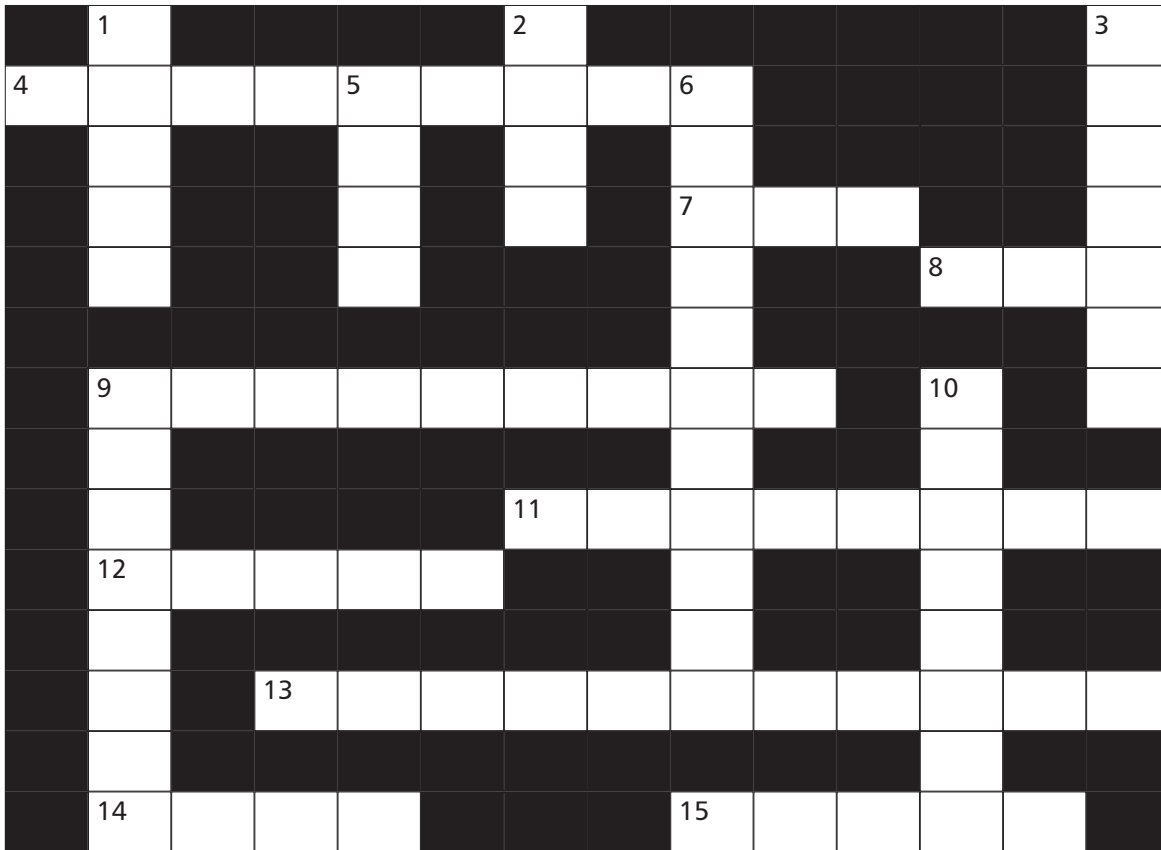

Across

- 4 Lowering the moisture content of timber is called _____ (9)
- 7 ___ _ splitting can happen if the moisture leaves the end of planks too quickly (3)
- 8 One way of drying timber is called natural or ___ _ seasoning (3)
- 9 One way of preventing end-splitting (9)
- 11 In a kiln temperature and _____ are controlled (8)
- 12 One of the advantages of air seasoning is that it is _____ (5)
- 13 In a kiln _____ and humidity are controlled (11)
- 14 A disadvantage of air/natural seasoning –drying is very _____ (4)
- 15 A moisture _____ is used to measure the moisture content of timber (5)

Down

- 1 In a kiln these allow wet air out and fresh air in (5)
- 2 This is a large sealed box used to dry out timber (4)
- 3 A way of drying out timber is air or _____ seasoning (7)
- 5 The _____ method is one way of measuring the moisture of timber (4)
- 6 The timber in newly felled trees is called G _____ T _____ (5,6)
- 9 Pieces of timber used to separate planks in a stack of timber for drying (8)
- 10 Newly felled timber contains a lot of M _____ (8)

Seasoning Wordsearch

S	E	A	S	O	N	I	N	G	A	B	O	C	I
T	G	I	C	D	E	F	A	G	H	I	V	J	N
A	K	R	M	O	I	S	T	U	R	E	E	G	S
C	L	M	E	N	O	P	U	Q	R	S	N	T	E
K	U	V	W	E	X	G	R	Y	Z	I	A	B	C
I	C	D	E	F	N	G	A	H	T	I	J	M	T
N	K	L	M	I	N	T	L	T	O	P	Q	E	S
G	R	S	Y	T	U	K	I	L	N	V	W	T	X
Y	Z	R	A	B	C	L	D	M	E	T	E	R	E
G	D	H	I	J	P	K	L	M	B	N	O	E	F
T	S	R	Q	S	S	T	I	C	K	E	R	S	P
U	V	W	D	X	Y	X	Q	G	J	K	R	O	P
F	G	N	J	K	L	E	T	Y	F	U	N	G	I
D	E	F	G	P	R	O	N	G	S	J	K	N	Q

Find the following list of keywords associated with timber seasoning in the grid above:

SEASONING	AIR	NATURAL	MOISTURE
GREENTIMBER	STICKERS	DRYING	END-SPLITTING
KILN	STACKING	OVEN	METER
PRONGS	INSECTS	FUNGI	

Targets 4 & 5

Computers & C.A.D.

Keywords

Computer	Monitor	Hard Disk	Keyboard	Mouse
Floppy Disk	Printer	Hardware	Software	Input
Output	Text	Graphics	Computer Aided Design	

The following is a typical set-up on a computer desk:

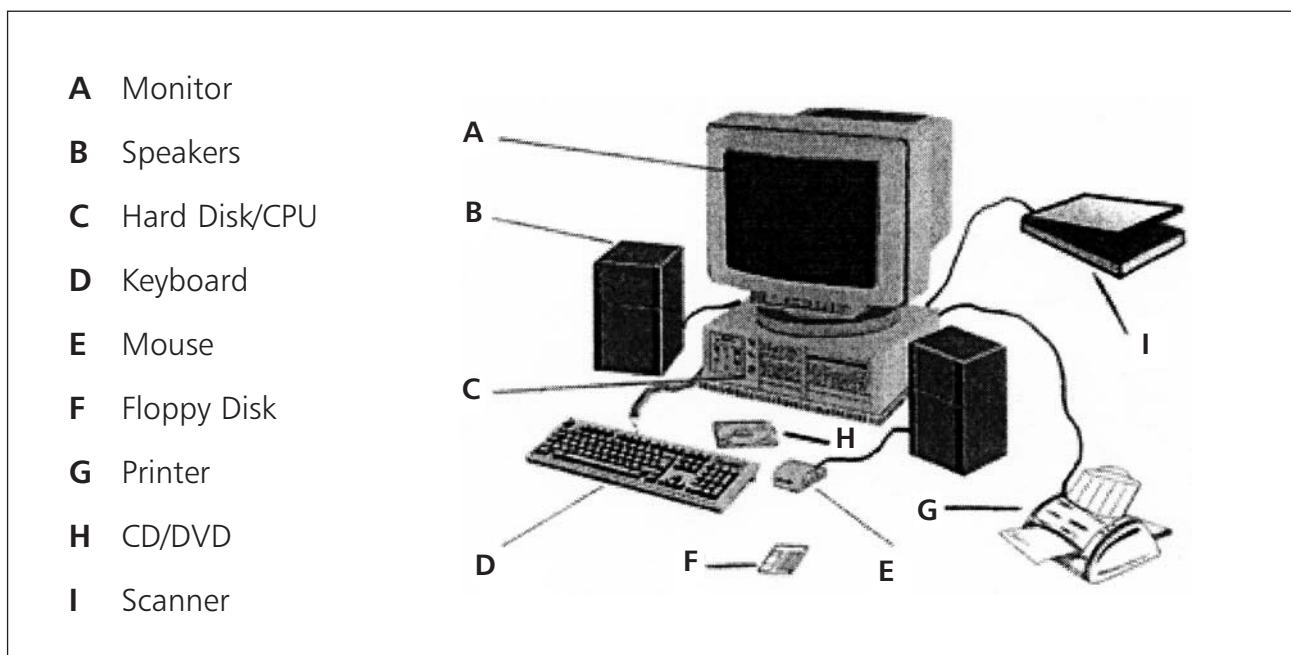

Hardware – the seen parts of the system e.g. hard drive, monitor, keyboard, mouse, printer etc

Software – programmes to allow the computer to be used e.g. windows, C.A.D. (Computer Aided Design) etc....

An **Input** device is used to put information into a computer while an **Output** device is for getting information out. Some devices can be both input and output, e.g. floppy disk. The following is a summary of information about the important computer components.

DEVICE	INPUT	OUTPUT	USE
Monitor		■	Colour screen displaying text and graphics.
Hard Disk	■	■	Where information is processed. It contains drives for floppy, CD and DVD disks.
Keyboard	■		Used to type information into the computer. The information shows up on the screen.
Mouse	■		Used to point to and select from menus on the monitor screen.
Printer		■	This produces a hard copy (printed copy of drawing or text documents)
Floppy Disk	■	■	Used to store information from a computer or to put information in.
Scanner	■		Used to copy an image from a page onto a computer screen.
CD-ROM	■	■	Like a floppy disk, this can be used to put in or store information from a computer.

Other Important Notes About Computers

- Always sit properly at a computer in a comfortable chair.
- Don't use a computer for too long at any one time to protect your eyes.
- Store floppy disks carefully as:
 - (i) The metal slide can be easily damaged.
 - (ii) Storing close to a magnetic field (present in tv.s, printers, etc.) can destroy data on the disk.
 - (iii) Direct heat can damage the plastic case.
 - (iv) Dirt, dust and liquid spills can also damage the data on the disk.
- Letters and numbers are called **Text** while pictures are called **Graphics**.
- When putting information on a computer it should be saved regularly because if the computer shuts down (e.g. a power cut) any information not saved will be lost.

C.A.D. (Computer Aided Design)

This is a very popular software package used to put design drawings on a computer. It is sold under the name **AUTOCAD**.

The advantages of having drawings stored on a computer are:

- Takes up very little space (100's of drawings can be stored on a single CD).
- Drawings can be easily sent to another computer anywhere.
- Changes can be made (or mistakes fixed) in seconds.

Worksheet on Computers & C.A.D.

1 Write the correct name for each computer component into the appropriate box.

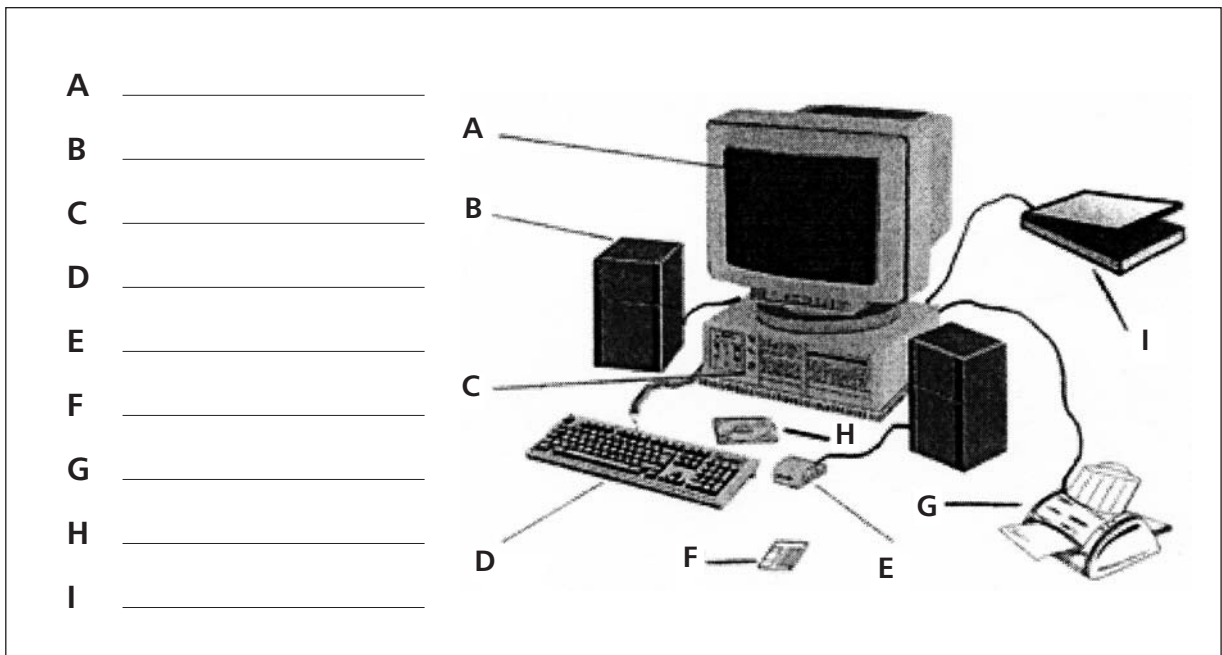

2 Indicate with an 'x' in the box if each of the computer components is an input and/or an output device. Also place the letter which matches its description into the last column.

DEVICE	INPUT	OUTPUT	LETTER
Monitor			
Hard Disk			
Keyboard			
Mouse			
Printer			
Floppy Disk			
Scanner			
CD-ROM			

- A Where information is processed
- B Used to copy an image from a page
- C Produces a hardcopy of an image
- D A computer screen
- E Disk-more solid than a floppy
- F Used to type in information
- G A square disk for holding data
- H moves an arrow around the screen

- 3 Place the following into the table under the correct heading: Hard Drive, C.A.D., Printer, Mouse, Windows, Keyboard.

Hardware	Software

- 4 Give 2 reasons why floppy discs should be stored carefully.

(i) _____

(ii) _____

- 5 Letters and numbers are called T _____ while pictures on a computer are called G _____ .

- 6 Why is it important to save information regularly when working on a computer?

- 7 What do the letters C.A.D. stand for?

C _____ A _____ D _____

- 8 List 2 advantages of having drawings stored on a computer.

(i) _____

(ii) _____

Target 6

Adhesives

Target 6

Adhesives

Keywords

Adhesive	Glue	Shelf Life	Pot Life
Bonding	PolyVinyl Acetate (P.V.A.)	Epoxy Resin	Closed Assembly Time
Contact/Impact	Hardener	Laminate	Veneering

Glue is a general term used for **Adhesives**.

It is important to choose the right adhesive for any particular job so a number of questions need to be asked.

- 1 What materials are being glued? (e.g. wood, metal or plastic)
- 2 Where will the piece be used after it is glued? (indoor or outdoor).

The following are three important terms used in relation to adhesives:

- 1 **Shelf Life:** This is the length of time an adhesive can be stored before opening. (Its "best before" date).
- 2 **Pot Life:** This is the amount of time before a glue "goes off" after it is opened/prepared.
- 3 **Closed Assembly Time:** This is the amount of time you have to adjust pieces after they are glued, before the final bond starts to form.

Important Glues to Know About

P.V.A. (Poly Vinyl Acetate) – This is the most common glue used on woodworking projects in schools. It is a thick white liquid and is bought in a plastic carton ready to use.

Advantages of P.V.A. for use in woodworking:-

- Inexpensive.
- Non-toxic.
- Easy to apply.
- Odourless.
- Long pot and shelf life.

Disadvantages of P.V.A. :-

- The pieces must be clamped for at least four hours.
- It can stain the wood.

Epoxy Resin – Usually sold in two parts (the resin and a hardener) to be mixed. This glue is not suitable for general woodworking. It is good for non-porous surfaces like metals and plastics.

Advantages of Epoxy Resins:-

- Water proof.
- Very strong bond.

Disadvantages of Epoxy Resins:-

- Very expensive.
- Sets very quickly.

Contact Adhesives (Rubber Based Adhesives)

These are supplied ready to use. Each surface to be glued is coated with a very thin layer of adhesive and allowed to become “touch dry”. The bond forms as soon as the two surfaces come in contact. It is not suitable for bonding woodworking joints but is used to bond **Plastic Laminates** to timber for worktops and for small areas of timber **Veneering**.

Advantages of contact adhesives:

- No pressure (clamping) needed to bond.
- Easy to apply.
- Very strong bond.

Target 6

Adhesives

Disadvantages of contact adhesives:



- Very quick bond (no time for adjustment).
- Harmful fumes.
- Strong smell.

The following table gives a quick guide to choosing an adhesive to bond different materials to each other:-

MATERIAL	WOOD	ACRYLIC (PERSPEX)	METAL	PLASTIC LAMINATE
Wood	P.V.A.	Epoxy Resin	Epoxy Resin	Contact/Impact
Acrylic (Perspex)	Epoxy Resin	Epoxy Resin	Epoxy Resin	Contact/Impact
Metal	Epoxy Resin	Epoxy Resin	Epoxy Resin	Contact/Impact
Plastic Laminate	Contact/Impact	Contact/Impact	Contact/Impact	Contact/Impact

Applying adhesives:

Applying adhesive depends on the type of glue being used and the job at hand. The following table gives a typical use and method of applying the adhesives above:

ADHESIVE	TYPICAL USE	METHOD OF APPLICATION
P.V.A.	Woodwork Joints	(i) Glue Brush (ii) Glue Stick (ii) Roller 
Epoxy Resin	Bonding Metals and Plastics	Glue Brush 
Contact/Impact	Plastic Laminates Veneering	Serrated Spreader Spray Gun 

Questions on Adhesives

1 What questions need to be asked when choosing an adhesive for any particular job?

- (i) _____

- (ii) _____

2 Explain the following terms

- (i) Shelf Life: _____

- (ii) Pot Life: _____

- (iii) Closed Assembly Time: _____

3 What do the letters P.V.A. stand for?

P _____ V _____ A _____

4 What is P.V.A. most used for in M.T.W.?

Target 6

Adhesives

5 List one advantage and one disadvantage of P.V.A.

(i) Advantage: _____

(ii) Disadvantage: _____

6 Epoxy Resin is a 2-part glue. Name the 2 parts.

(i) _____ (ii) _____

7 Name two materials which can be bonded together using Epoxy Resin.

(i) _____ (ii) _____

8 List one advantage and one disadvantage of Epoxy Resin.

(i) Advantage: _____

(ii) Disadvantage: _____

9 What are Contact/Impact adhesives most suitable for bonding?

Target 6

Adhesives

10 List one advantage and one disadvantage of Contact/Impact adhesives.

(i) Advantage: _____

(ii) Disadvantage: _____

11 Complete the following table.

MATERIAL	WOOD	ACRYLIC (PERSPEX)	METAL	PLASTIC LAMINATE
Wood				
Acrylic (Perspex)			Epoxy Resin	Contact/Impact
Metal		Epoxy Resin		Contact/Impact
Plastic Laminate		Contact/Impact	Contact/Impact	

12 Complete the following table.

ADHESIVE	TYPICAL USE	ONE METHOD OF APPLICATION
P.V.A.	_____ _____	_____
Epoxy Resin	_____	_____
Contact/Impact	_____	_____

Adhesive Crossword

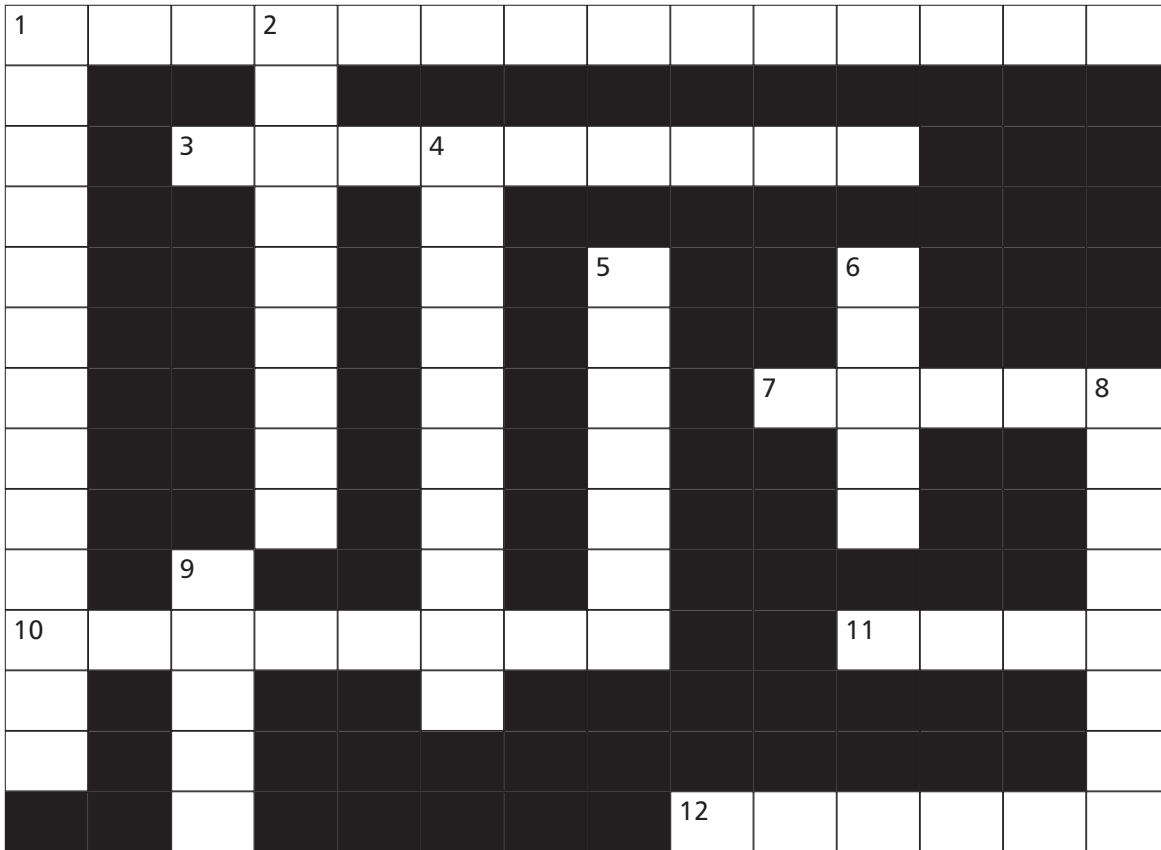

Across

- 1 Time available for adjusting pieces after they are glued _____ time (6,8)
- 3 The process of using contact/impact adhesive to cover a backing piece with a thin sheet of timber. (9)
- 7 Glue _____ is one method of applying P.V.A. glue. (5)
- 10 Glue is the general term for this. (8)
- 11 The general term for adhesive. (4)
- 12 A hand held _____ can be used to spread P.V.A. glue over a large area. (6)

Down

- 1 A type of glue used for laminating and veneering is _____ / _____ (7,6)
- 2 An adhesive's "best before" date _____ (5,4)
- 4 Glue used for bonding metals and plastics. _____ (5,5)
- 5 P.V.A. stands for PolyVinyl _____ (7)
- 6 Used to apply glue to large areas _____ gun. (5)
- 8 Epoxy Resin glue is a two part glue made up of the resin and a _____ (8)
- 9 This is the colour of P.V.A. glue (5)

Target 6

Adhesives

Adhesive Wordsearch

C	L	O	S	E	D	A	S	S	E	M	B	L	Y
O	A	A	Q	W	E	R	H	G	P	T	O	U	I
N	M	H	J	K	R	L	E	L	O	L	N	K	G
T	I	S	X	C	O	V	L	N	X	A	D	P	L
A	N	P	O	T	L	I	F	E	Y	C	I	O	U
C	A	R	Z	X	L	X	L	C	R	E	N	L	E
T	T	A	N	M	E	M	I	B	E	T	G	Y	B
Q	E	Y	W	E	R	R	F	T	S	A	Y	V	R
A	D	H	E	S	I	V	E	G	I	T	H	I	U
Q	W	E	R	H	A	R	D	E	N	E	R	N	S
V	E	N	E	E	R	I	N	G	F	G	H	Y	H
Z	X	C	I	M	P	A	C	T	T	V	B	L	N

Find the following list of keywords associated with adhesives, in the grid above:

ADHESIVE

SHELF LIFE

POT LIFE

CLOSED ASSEMBLY

POLYVINYL

ACETATE

CONTACT

IMPACT

VENEERING

EPOXY RESIN

HARDENER

GLUE BRUSH

ROLLER

LAMINATE

BONDING

SPRAY

Targets 7 & 8

Conversion of Timber

Keywords

Felling	Logs	Planks	Conversion
Through	Quarter	Radial	Tangent
Silver Grain	Cupping	Warping	

FELLING is the term given to the cutting down of trees.

The crown and branches are removed and used for **PARTICLE BOARDS** and **PAPER MAKING**.

The bark is removed and used for **GARDEN MULCH**.

CONVERSION OF TIMBER means cutting a round log into planks of different sizes.

Three Methods of Conversion are:

- 1 Through and Through Sawing
- 2 Quarter Sawing (Radial Sawing)
- 3 Tangent Sawing

1 Through and Through Sawing

Logs are sawn into planks by a large bandsaw using straight, parallel cuts as shown in the diagram. It produces very wide and very narrow planks. This is the most common method used in Ireland.

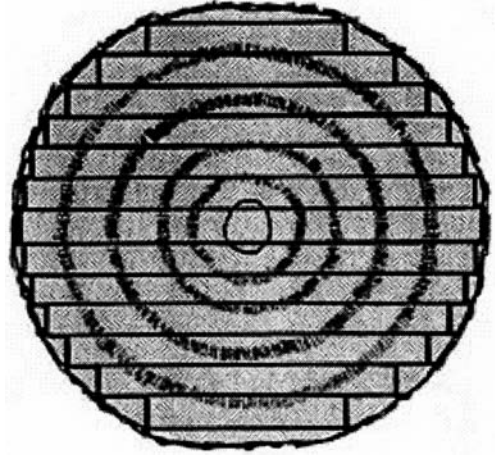

Advantages of this method:

- Cheap.
- Fast.
- Little waste.
- Not much labour needed.

Disadvantages:

- Causes a lot of cupping and warping.
- Planks not very strong.

2 Quarter Sawing

This method is also known as Radial sawing. The planks are sawn as shown in the diagram. The log must be turned a lot during the process. Some of the planks are very narrow. Quarter sawn oak shows an attractive pattern called **'Silver Grain'**

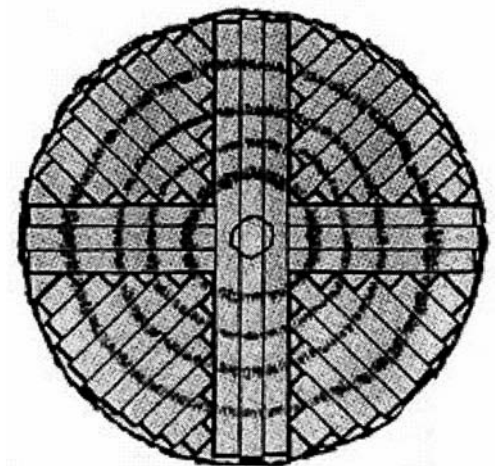

Advantages of this method:

- Planks very strong.
- Very attractive grain patterns can be got.
- Little shrinking and cupping.
- Boards are very hardwearing(flooring).

Disadvantages:

- Expensive.
- Lot of waste.
- Takes a long time because of turning the log.

3 Tangent Sawing

The planks are sawn as shown in the diagram. Again the log must be turned a lot to make all the cuts.

Advantages of this method:

- Strong boards.
- Attractive grain.
- Less chance of boards splitting.
- Hardwearing.

Disadvantages:

- Expensive.
- Lot of waste.
- Takes a long time because of turning the log.
- Narrow boards.

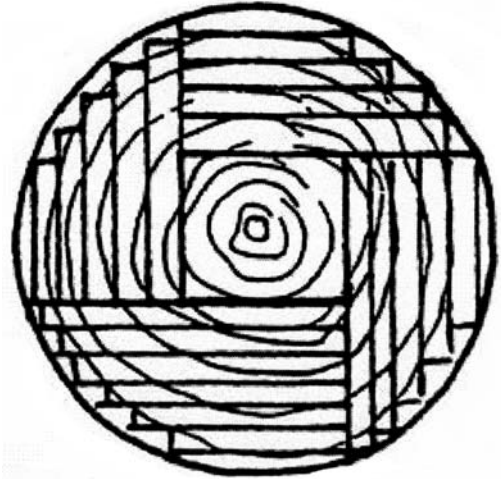

Questions on Conversion of Timber

1 What is the term used for the cutting down of trees?

2 What use is made of the branches that are stripped from the tree after it is cut down?

3 What is the bark used for?

4 What is meant by the term 'conversion of timber'?

5 (a) Name the method of conversion shown in the diagram.
(b) Copy the diagram into the box.

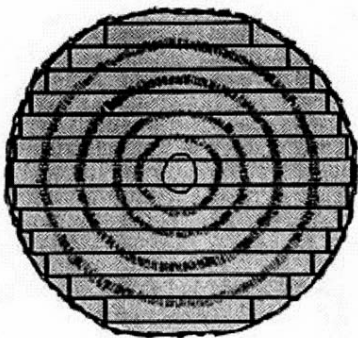

Name?

Targets 7 & 8

Conversion of Timber

6 List 3 advantages of this method of conversion.

7 List 2 disadvantages of this method.

8 (a) Name the method of conversion shown in the diagram.
(b) Copy the diagram into the box.

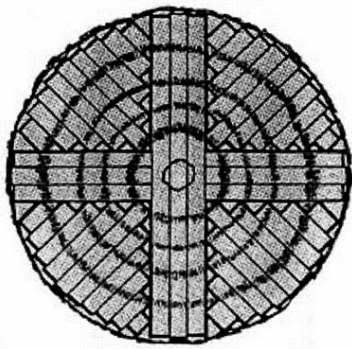

Name?

9 List 3 advantages of this method of conversion.

10 List 3 disadvantages of this method.

11 (a) Name the method of conversion shown in the diagram.
(b) Copy the diagram into the box.

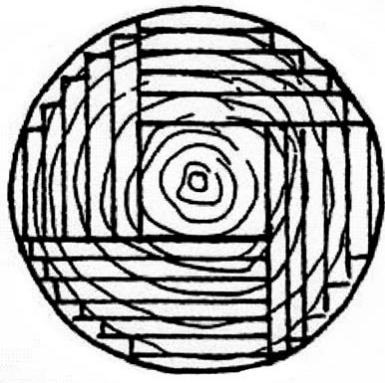

Name?

12 List 3 advantages of this method of conversion.

13 List 3 disadvantages of this method.

Conversion of Timber Crossword



Across

- 1 Branches stripped from trees can be used in P _____ (11)
- 3 Boards cut using 'quarter sawing' are very H _____ (11)
- 6 S _____ G _____ is an attractive grain pattern seen in oak which is quarter sawn (11)
- 7 These are stripped from the tree after felling (8)
- 10 Another name for quarter sawing is R _____ sawing (6)
- 11 This is the name given to the cutting down of trees (7)
- 12 The cheapest method of conversion is called through and _____ Sawing (7)

Down

- 2 Conversion of timber means changing from a log into P _____ s (6)
- 4 One method of conversion is called T _____ sawing (7)
- 5 The cutting of logs into planks is called C _____ of timber (10)
- 8 One disadvantage of through and through sawing is a lot of C _____ (7)
- 9 With through and through sawing there is very little W _____ (5)

Conversion of Timber Wordsearch

H	T	A	B	C	D	R	E	F	G	H	I	J	P
P	A	P	E	R	M	A	K	I	N	G	G	K	L
Q	N	R	W	E	R	D	T	Y	U	N	I	O	A
A	G	S	D	F	G	I	H	J	I	J	K	L	N
Z	E	X	C	W	V	A	N	P	F	M	M	N	K
B	N	Q	W	A	E	L	R	E	E	R	T	T	S
R	T	Y	U	S	I	A	M	U	L	C	H	I	O
A	Z	X	C	T	W	B	R	N	L	M	R	B	C
N	V	B	B	E	N	K	M	I	I	X	O	X	Z
C	O	N	V	E	R	S	I	O	N	N	U	M	M
H	Q	Z	X	A	N	M	M	M	G	G	G	W	Q
E	Z	X	B	G	Z	X	Q	K	M	Z	H	Z	Q
S	I	L	V	E	R	G	R	A	I	N	V	Z	Q
Q	U	A	R	T	E	R	C	U	P	P	I	N	G

Find the following list of keywords associated with conversion of timber in the grid above:

HARDWEARING

PAPER MAKING

TANGENT

RADIAL

CONVERSION

FELLING

MULCH

BRANCHES

SILVER GRAIN

WARPING

WASTE

BARK

THROUGH

CUPPING

PLANKS

Targets 9 & 10

Veneering, Marquetry, Parquetry & Inlaying

Keywords

Veneer	Rotary	Groundwork	Plywood
Marquetry	Parquetry	Inlaying	Motif
Veneer Hammer			

A **VENEER** is a thin slice of wood, cut from a log. Two ways of cutting veneers are:-



Rotary Cutting



Flat Slicing

Very thin veneers are used in **VENEERING**. This is the gluing of veneers onto a backing piece known as **GROUNDWORK**, which is usually a manufactured board such as chipboard or M.D.F.

Thicker veneers are used to make plywood itself. This is done by gluing the sheets of veneer together as shown in the diagram:

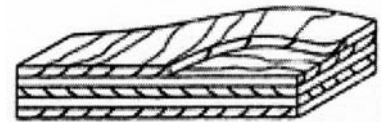

Adhesives used in veneering

The most common glue used nowadays is **CONTACT/IMPACT** adhesive. **P.V.A.** (Polyvinyl Acetate) is also used.

Reasons for using each:

Contact/Impact-

- Needs very little pressure to glue the veneer to the groundwork.
- Very strong, instant bond.

P.V.A.

- For complicated veneering, it allows enough time to fix the veneers in place before 'going off'.
- It does not stain/it dries clear.

Applying contact/impact adhesive:

- 1 Brush a coat of the glue onto the veneer and the groundwork.
- 2 Leave for a few minutes until it is touch dry.
- 3 Place a sheet of paper on the groundwork just down from the top.
- 4 Position the veneer on the groundwork and press down.
- 5 Remove the paper and use a block to press the veneer to the groundwork as the paper is slipped out. The bond is formed very quickly.

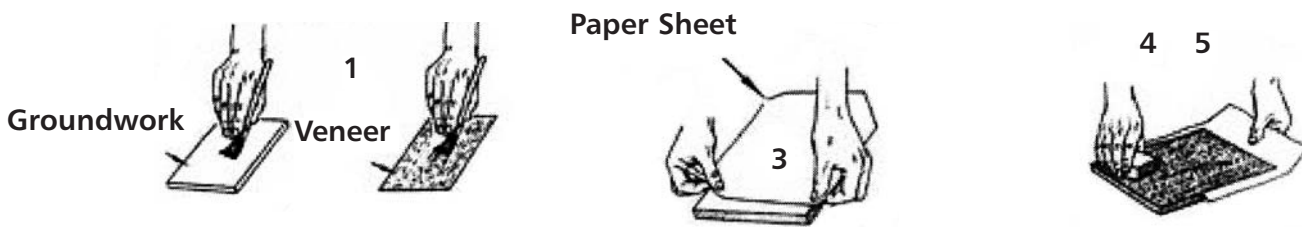

(Applying P.V.A. is done as part of the next section)

How to insert a motif into a veneer.

(A motif is a ready-made decorative piece of veneer)

- 1 Place the diamond motif in the centre of the veneer.
- 2 Tape the motif to the veneer.
- 3 Carefully cut around the motif using a scalpel (knife) cutting the shape into the back veneer.
- 4 Remove the shape from the back veneer and replace it with the motif, which should fit exactly.

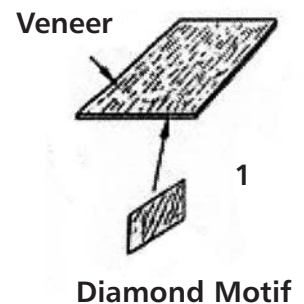

Fixing the veneer (with the motif) onto groundwork using P.V.A.

- 1 Brush a thin coat of P.V.A. onto the groundwork only.
- 2 Place the veneer on the groundwork.
- 3 Put the motif in the space and tape it down.
- 4 Clamp the veneers to the backing piece using timbers and G-cramps (place paper between the timbers and the veneer).
- 5 When dry, trim the edges with a knife and
- 6 Clean the surface using very fine sandpaper.

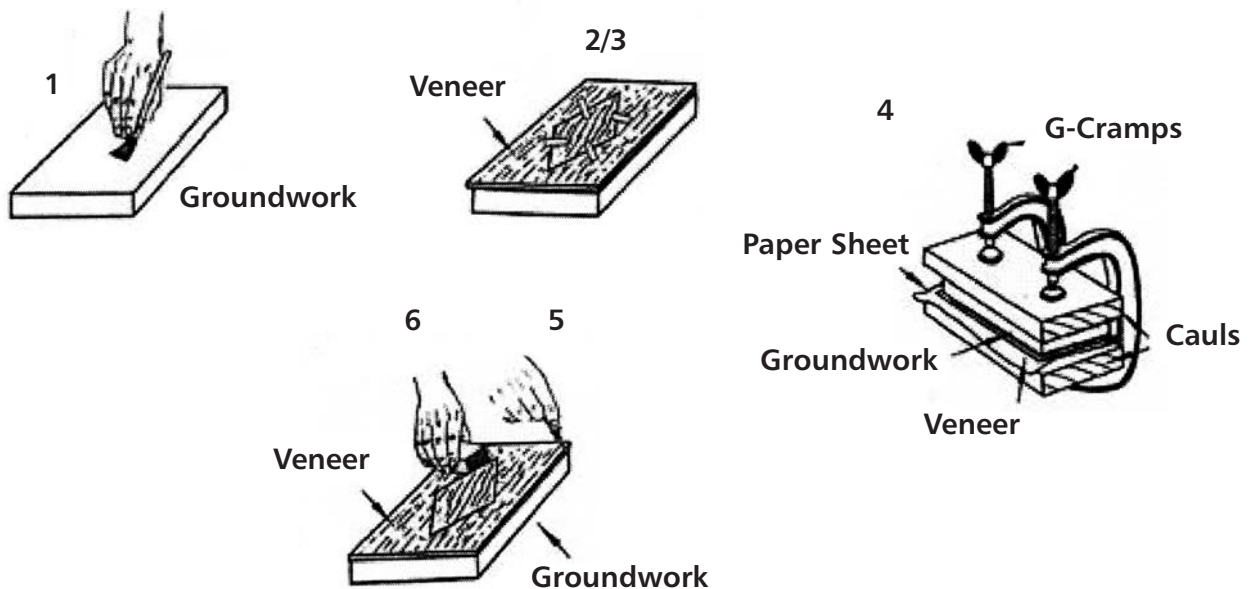

Advantages of veneering:

Using veneers of expensive timbers on cheap groundwork like chipboard will:

- save money.
- save on the use of rare, expensive timbers.
- help the environment by using trees sparingly.

Marquetry

This is the process of using veneers from different timbers to make decorative pictures and patterns. The various timbers show many different colours and grain patterns.

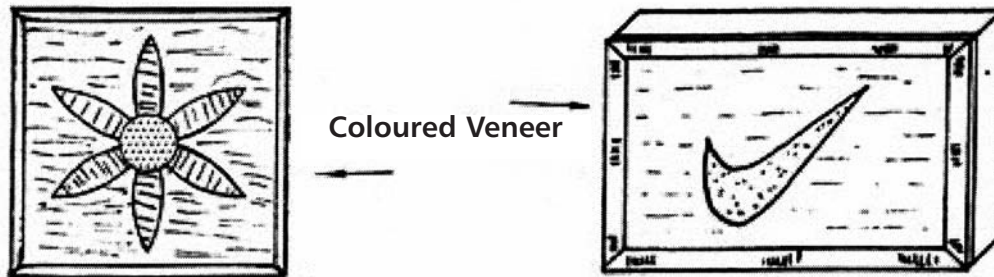

Parquetry

This is similar to marquetry but the design is made by cutting the veneers into simple geometric shapes like squares, triangles etc. A simple example of this is a veneered chess board using light and dark coloured timbers to make up the grid.

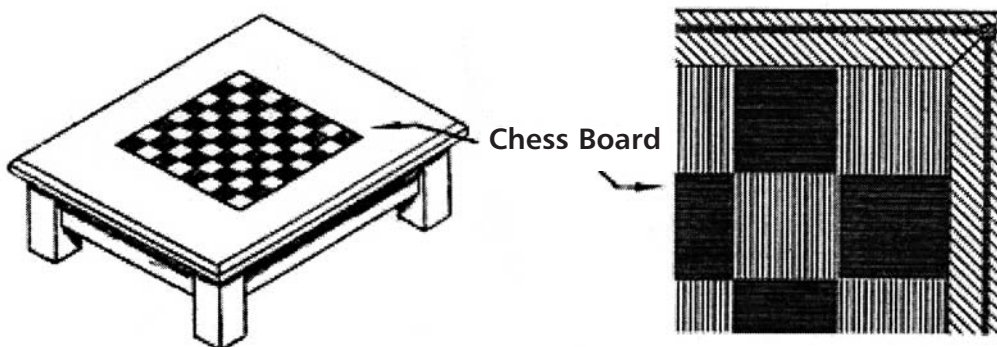

Inlaying

This is the process of inserting one piece of wood into another of different colour to create a decorative effect. A groove is removed from one of the timbers and filled with a strip of the other.

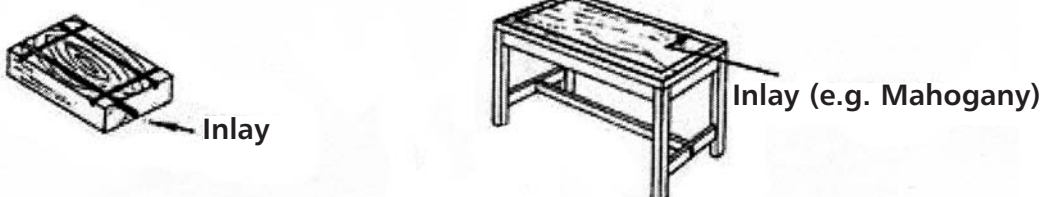

Worksheet on Veneering

1 Name each of the methods of cutting veneers from a log shown:

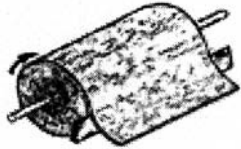

(i) _____ (ii) _____

2 Veneering is the process of gluing veneers onto a backing piece known as _____.

3 Name two manufactured boards used as backing pieces for veneering:

(i) C _____ (ii) M _____

4 Thick veneers are glued together to make the manufactured board shown in the diagram. What is it called?

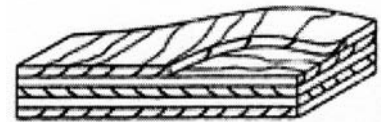

Name: _____

5 Name two adhesives used in veneering and give one reason why each is used.

Name: _____

Reason: _____

Name: _____

Reason: _____

Targets 9 & 10

Veneering, Marquetry, Parquetry & Inlaying

6 Write a note on what is happening in each diagram and state which type of glue is being applied:

Glue Used: _____

- (i) _____

- (ii) _____

- (iii) _____

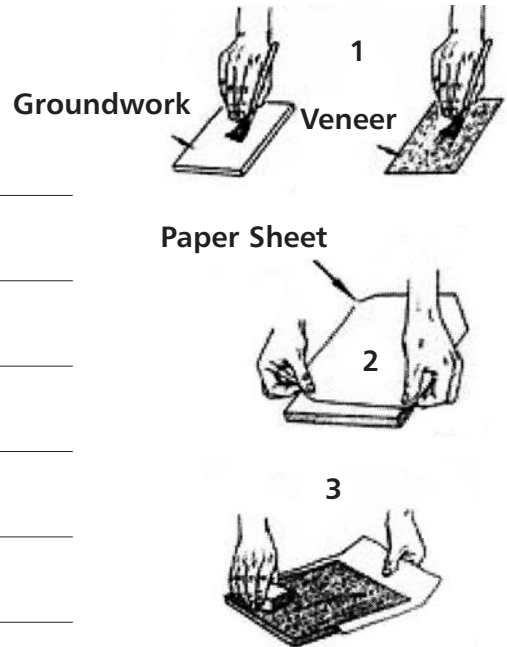

7 List the steps involved in inserting a motif into a veneer as shown.

- (i) _____

- (ii) _____

- (iii) _____

- (iv) _____

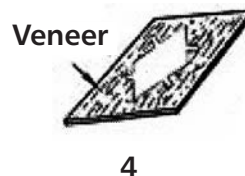
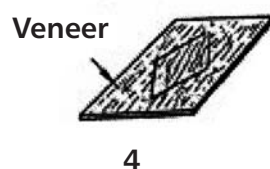
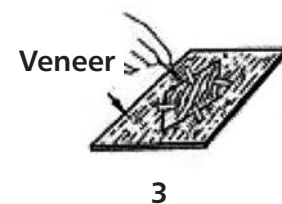
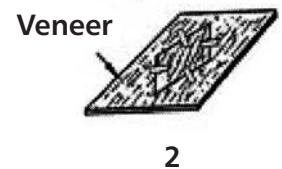
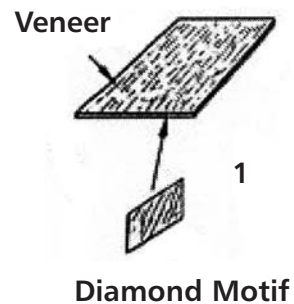

Targets 9 & 10

Veneering, Marquetry, Parquetry & Inlaying

8 Write a note on each of the stages involved in fixing a veneer with a motif to groundwork as shown. Also state what glue is being used.

Glue Used: _____

(i) _____

(ii) _____

(iii) _____

(iv) _____

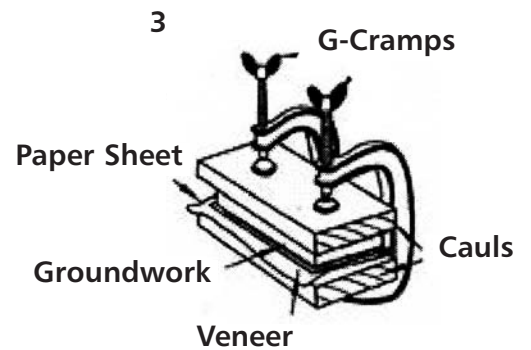
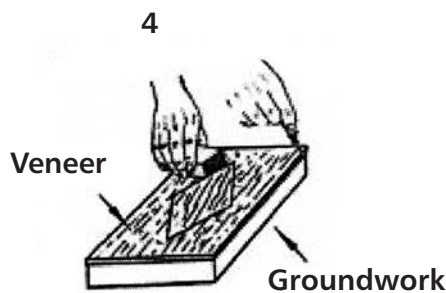
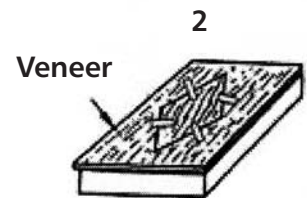
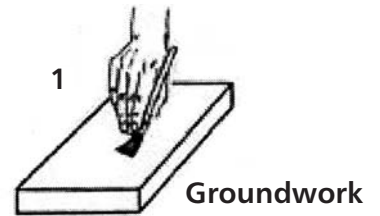

9 List two advantages of veneering.

(i) _____

(ii) _____

Targets 9 & 10

Veneering, Marquetry, Parquetry & Inlaying

10 From the given list, name the process involved in producing the following decorative pieces:

LIST
(a) Parquetry
(b) Inlaying
(c) Marquetry

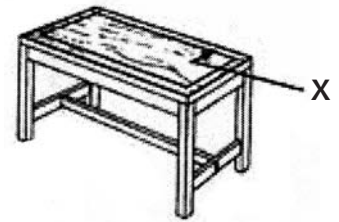

Process Involved: _____

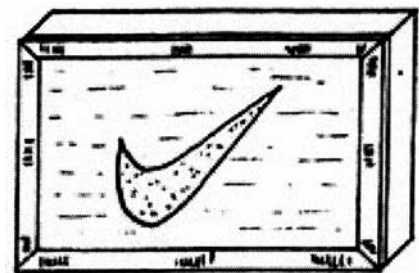

Process Involved: _____

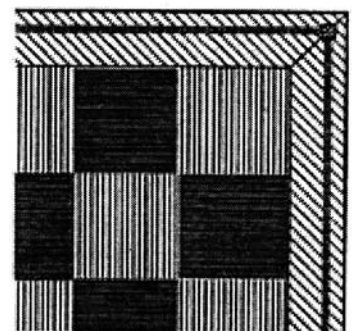

Process Involved: _____

Veneering Crossword

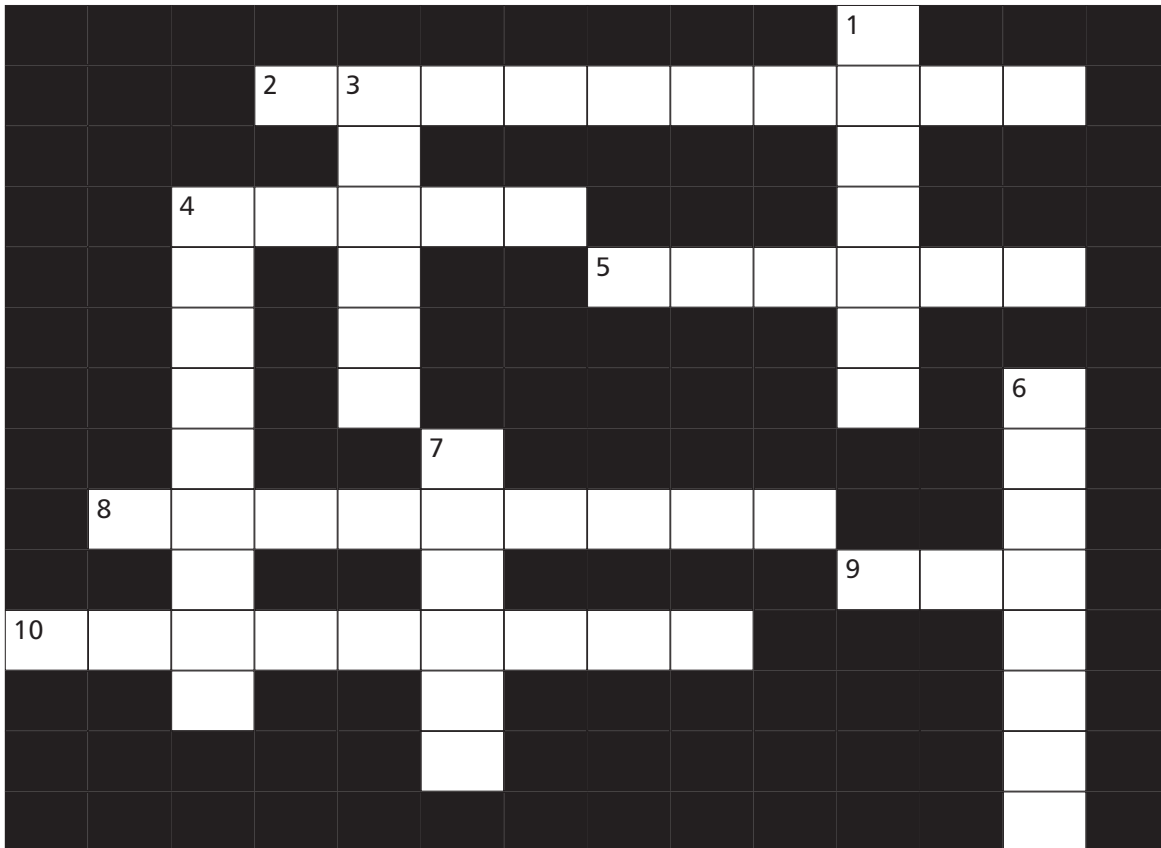

Across

- 2 This is the name given to the backing piece used for gluing veneers. (10)
- 4 A ready-made decorative piece of veneer is called a _____ (5)
- 5 Contact/_____ adhesive is a common glue used in veneering. (6)
- 8 This is the process of gluing veneers onto backing pieces. (9)
- 9 These are three letters used for the name of a glue used for complicated veneering. (3)
- 10 P_____ is the name given to the use of simple geometric shapes in veneering (e.g. in making a chess board). (9)

Down

- 1 C_____/Impact adhesives is a common glue used in veneering. (7)
- 3 This is one method of cutting veneers. (6)
- 4 This is the process of using veneers from different timbers to make decorative patterns or pictures. (9)
- 6 I_____ is the process of inserting strips of wood into grooves in a different colour wood. (8)
- 7 This is a thin slice of wood cut from a log. (6)

Targets 9 & 10

Veneering, Marquetry, Parquetry & Inlaying

Veneering Wordsearch

A	V	E	N	E	E	R	I	N	G	T	X	O	P
F	R	C	R	A	N	X	M	P	R	I	N	Z	Y
B	I	O	M	R	O	E	P	L	A	R	M	T	G
E	P	N	U	T	I	N	A	U	T	P	A	S	R
M	U	T	O	R	Y	A	C	A	T	E	R	Y	O
O	P	A	R	Q	U	E	T	R	Y	K	Q	J	U
T	I	C	P	O	K	S	U	O	N	T	U	O	N
I	M	T	U	Z	P	L	C	T	A	R	E	S	D
F	P	S	L	I	R	O	U	A	Z	S	T	Z	W
R	V	H	V	E	N	E	E	R	Y	U	R	I	O
A	A	O	B	C	T	I	S	Y	R	L	Y	C	R
T	T	R	R	K	L	Z	O	K	S	M	I	T	K
U	O	K	U	I	M	S	A	G	I	O	P	R	A
X	Y	I	N	L	A	Y	I	N	G	Z	K	I	L

Find the following list of keywords associated with veneering in the grid above:

VENEERING

MOTIF

MARQUETRY

PARQUETRY

IMPACT

VENEER

GROUNDWORK

INLAYING

ROTARY

CONTACT

P.V.A.

MTW Statement Code no: 7 Theory 3

Target 1

Inside a Plug

Target 1

Inside a Plug

Keywords

Plug

Live

Neutral

Earth

Fuse

The following is a typical set-up inside a plug:

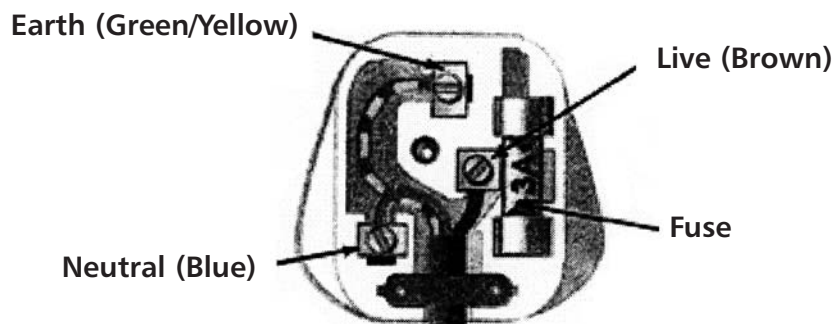

Three wires with different coloured covering are connected to three separate terminals (neutral, live and earth) positioned left right and top of the plug. This information is contained in the following table:

TERMINAL	NAME	COLOUR
Left	Neutral	Blue
Right	Live	Brown
Top	Earth	Green/Yellow

Safety: The purpose of the fuse in a plug is to protect the appliance which is being plugged in. It has a thin wire inside which will break and stop the flow of electricity if there is an overload.



Thin Wire

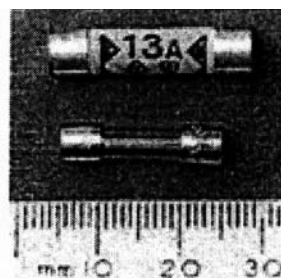

Target 1

Inside a Plug

Worksheet on the Plug

1 Indicate on the diagram, using the appropriate number, the position of the three terminals and the fuse.

1 Neutral (Blue)

2 Live (Brown)

3 Earth (Green/Yellow)

4 Fuse

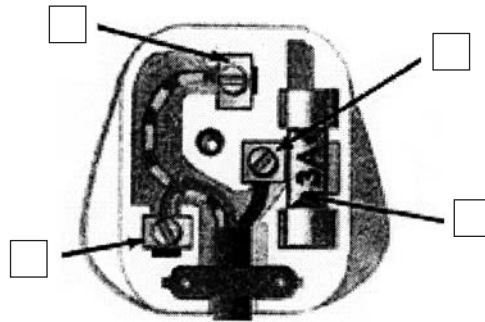

2 Fill in the correct colours into the table.

TERMINAL	NAME	COLOUR
Left	Neutral	
Right	Live	
Top	Earth	

3 Draw a diagram of a fuse in the box below.

4 How does a fuse work as a safety device in a plug?

Target 1

Inside a Plug

**Targets
2, 3 & 4**

Woodturning

Keywords

Lathe	Woodturning	Headstock	Tailstock	Tool Rest
Banjo	Faceplate	Gouges	Scrapers	Parting Tool
Spindle	Skew Chisel	Callipers	Template	Drive Centre

Woodturning is the art of using various shaped tools to convert a **blank** piece of timber into cylindrical shapes using a machine known as a **Lathe**.

There are basically two types of turning: (1) **Between Centres** (spindle) turning for table and chair legs and (2) **Faceplate** (bowl) turning for rounding bowls and plates.

The Lathe

- A Headstock
- B Tail stock
- C Drive Spindle
- D Banjo
- E Tool Rest
- F On/Off Buttons
- G Handwheel
- H Tightening Handles

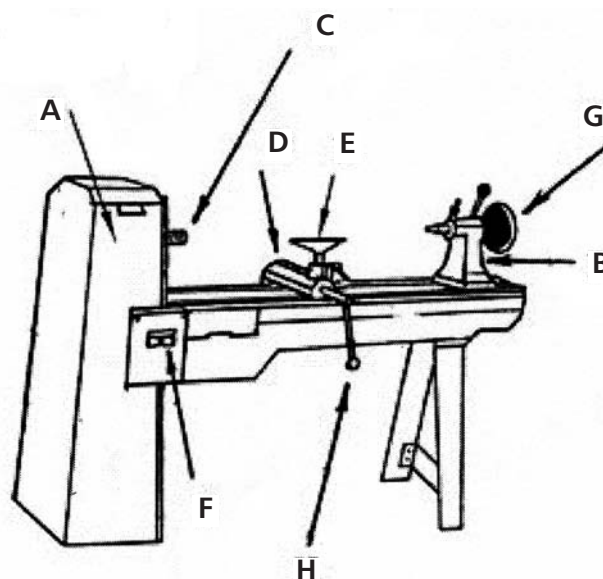

Parts of the Lathe:

Headstock – This houses the motor and pulley system (can be adjusted to vary the speed) used to drive a threaded spindle. As a rule the bigger the piece to be turned the slower the speed used.

Tailstock – This is moveable to allow for different lengths of timber to be turned. It can hold various types of centres such as:

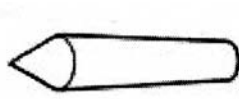

Dead Centre



Live Centre

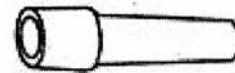

Hollow Cup Centre

Drive Centre – This is fitted to the drive spindle and grips the piece by its prongs to rotate it while turning.

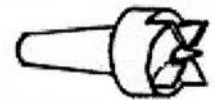

On/Off Buttons – Located on or near the head stock. It is important to know their position for safety reasons.

Tool Rest – This is adjustable and held in the **Banjo**. It is used to support the woodturning tools while turning.



Faceplate – Usually connected to the threaded spindle. The blanks are screwed to it for turning bowls and plates.



Safety in using the Lathe

- Always wear a protective visor when turning.
- Unplug the machine while setting up a blank for turning.
- Know the position of the off button.
- Make sure the piece is free from knots and splits.
- Make sure the piece is well secured on the lathe.
- Select the correct speed for the size of piece being turned.
- No loose clothing or jewellery and tie up long hair.
- When **SANDING** the piece, make sure to wear a dust mask/respirator and hold the sandpaper under the wood.

Suitable timber for turning: Most woods can be turned but hardwoods finish better than softwoods. Red deal (softwood) is good for use in school (knot free). Hardwoods like Beech, Chestnut, Elm, Sycamore and Ash are ideal

Tool used for Woodturning

The basic set of woodturning tools contains six pieces :

1 Roughing out gouge – this is used to turn a square or octagonal blank into a cylinder

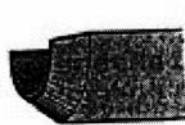

2 Spindle gouge – this takes over from the roughing out gouge for further shaping of the piece.

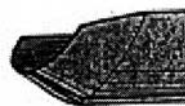

3 Bowl gouge – takes out large sections of timber from bowls.



4 Skew chisel – used to give a fine finish to any rough gouge work.



Targets 2, 3 & 4

Woodturning

5 **Parting tool** – used to make thin grooves in the wood the thickness of the blade, and for finishing ends before taking the piece off the lathe.



6 **Scraper** – used to put a smooth finish inside a bowl.



Important extra tools include an **inside** and **outside callipers** which are used for checking diameters when turning.

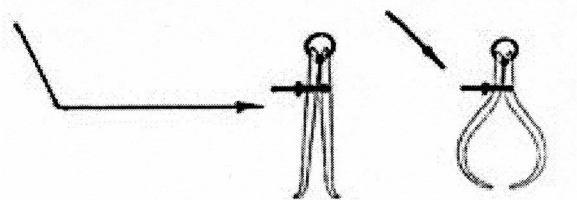

Using a template profile

If the piece to be turned is more complicated than a simple cylinder or if you need to turn more than one of the same piece, it is a good idea to make a template of the profile of the piece to be made.

- 1 Draw the outline (profile) of the piece onto a thin sheet of hardboard, plywood or M.D.F.
- 2 Use this template to ensure the piece being turned follows the exact profile as shown.

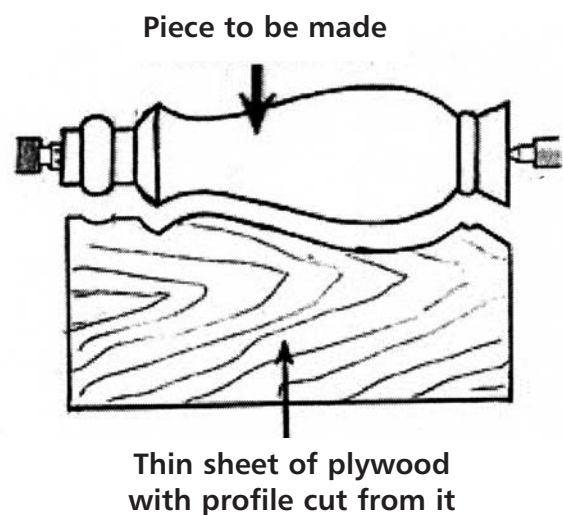

To copy the first piece above:

- 1 Use the back of the template to mark, with a pencil, where cuts need to be made on the piece.
- 2 Use the profile to check the piece as it is being turned.

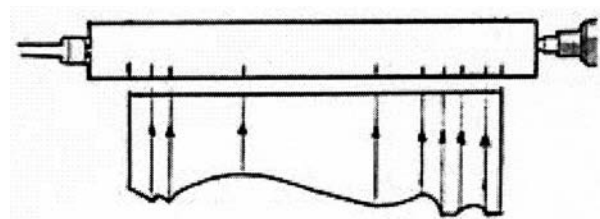

Preparing and mounting a piece for 'between centres' turning

- 1 Draw diagonal lines on the ends of the piece.
- 2 Draw the largest circle possible at both ends.
- 3 Make an octagon shape at each end as shown.
- 4 Plane off the corners to leave the octagon shape (this makes turning on the lathe easier with less waste to be removed).
- 5 Tap the 'drive centre' from the headstock into the end grain of the piece.
- 6 Slip this end of the piece into the prongs of the drive centre on the lathe and move the tailstock up to the other end of the piece.
- 7 Clamp the tailstock to the bed of the lathe. Use the wheel to push the centre into the piece and clamp it in place.
- 8 Set the tool rest in place and you are ready for turning.

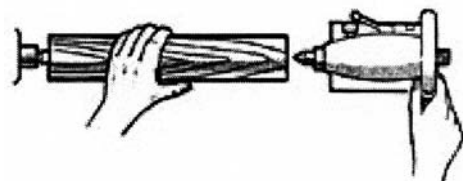
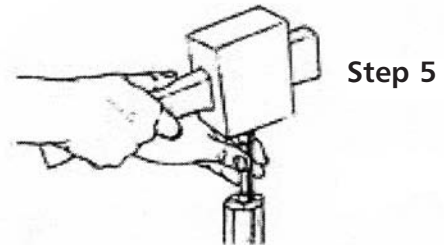
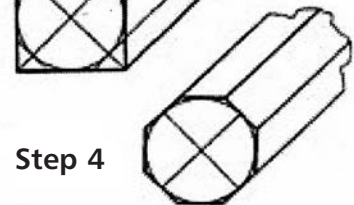
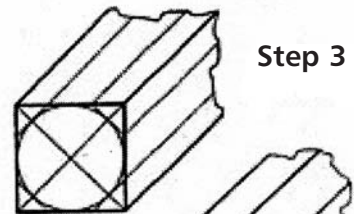
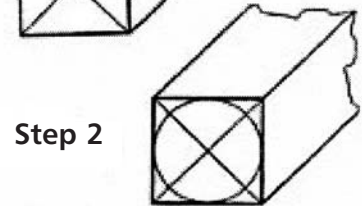

Preparing and mounting a piece for 'bowl' turning

- 1 Draw the diagonals on the face of the piece.
- 2 Draw a circle slightly larger than the bowl to be turned.
- 3 Use a curve cutting saw to remove the waste.
- 4 Centre the 'face plate' on the piece and screw it on using short screws.
- 5 Thread the plate onto the drive spindle.
- 6 Set up the tool rest and start turning.

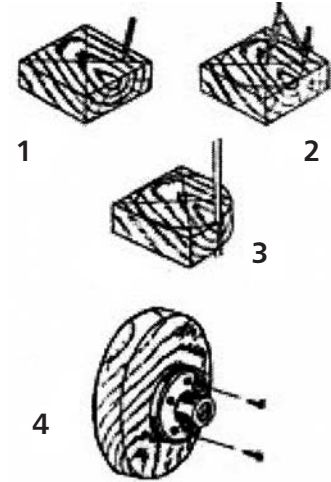

Using a 'Long Hole Boring Auger'

- This is used to bore a hole through the length of the piece to allow a flex up the centre for a lamp.
- A hollow cup centre must be used to grip the piece at the tailstock. This allows the auger bit to pass through the tailstock and on up through the piece.
- The piece is then reversed and rest of the length is bored.

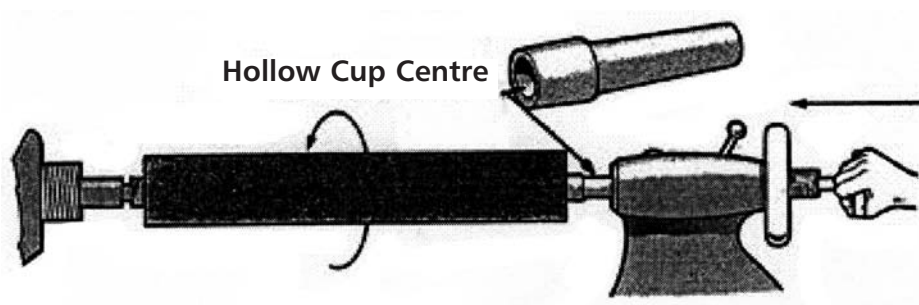

Questions on Woodturning

1 Identify the various parts of the lathe by entering the appropriate letter into the associated boxes in the diagram.

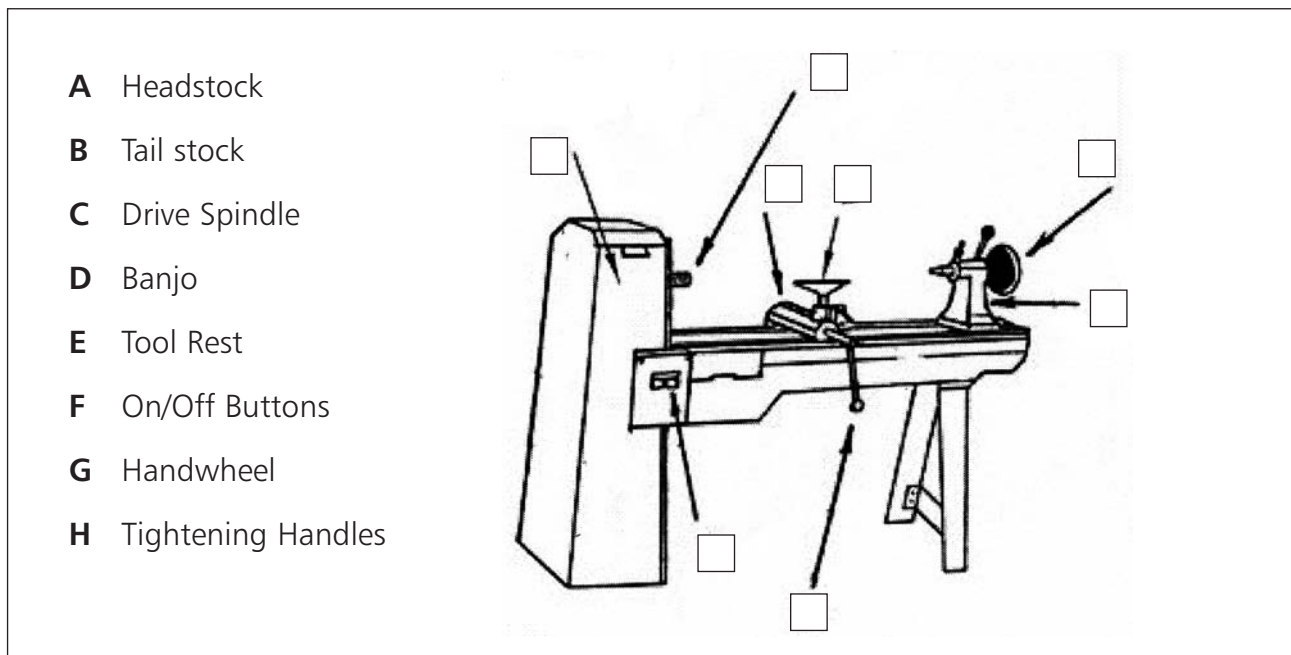

2 What is the purpose of each of the following parts of the lathe?

HEADSTOCK: _____

TAILSTOCK: _____

DRIVE CENTRE: _____

TOOL REST: _____

Targets 2, 3 & 4

Woodturning

- 3 Choose the correct speed for turning (a) an egg cup and (b) a large bowl and enter it into the appropriate box in the table.

Speeds: 1,500 r.p.m.
300 r.p.m.

ITEM	SPEED
Egg Cup	
Large Bowl	

- 4 List safety rules associated with using the lathe (some words are provided to help you).

Face protection: _____



Dust from sanding: _____

Mounting the piece: _____

Clothes/hair: _____

Speed of rotation: _____

Holding tools: _____

5 Fill in the table below using the list of uses given.

- Use:** Takes out large sections of bowl waste.
 Turns an octagonal piece to a cylinder.
 Puts a smooth finish inside a bowl.
 Makes thin grooves in the wood.
 Shapes the piece after roughing out.

TOOL NAME	USE
Parting Tool	
Bowl Gouge	
Skew Chisel	
Spindle Gouge	
Scraper	

6 Name the tools shown for checking diameters.

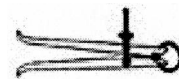
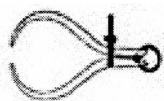

(i) _____ (ii) _____

7 Explain what is happening in the diagram showing the **template profile**.

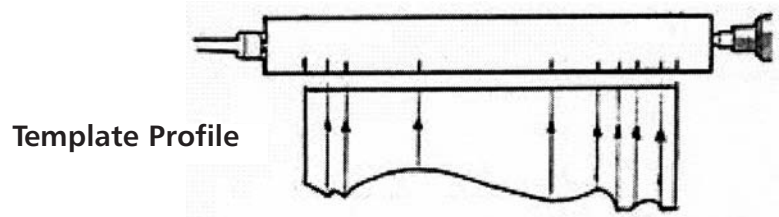

8 Explain the steps shown for preparing a piece for mounting on a lathe.

(i) _____

(ii) _____

(iii) _____

(iv) _____

(v) _____

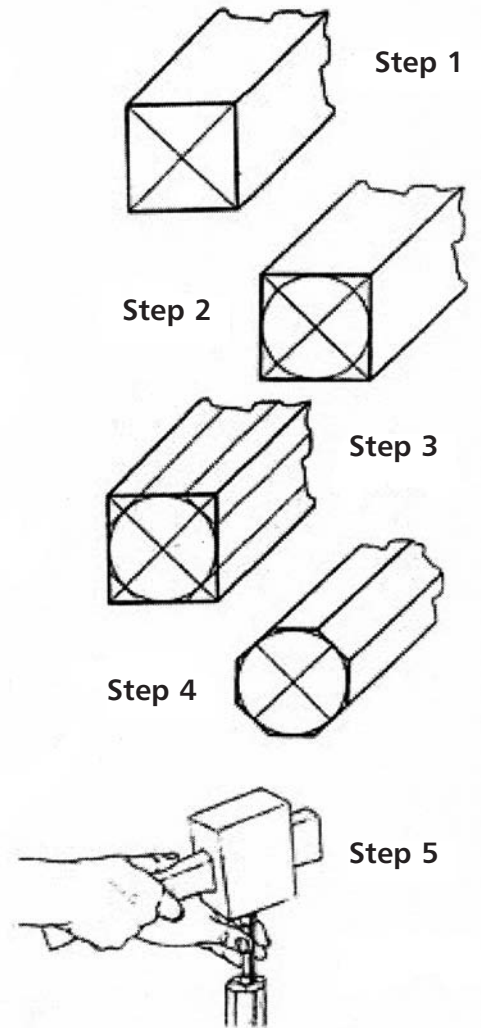

- 9 Complete the following sentences associated with mounting a piece on a lathe, using the following list of keywords: **TOOL REST, DRIVE, GRAIN, PRONGS, CORNERS, HEADSTOCK, OCTAGON, and TAILSTOCK.**

Plane off the _____ to leave an _____ shape.
 Tap the _____ centre from the _____ into the end _____
 of the piece. Clamp the piece between the _____ of the drive spindle and the
 centre in the _____. Set the _____ _____ in place and
 start turning.

- 10 Put the following steps for bowl turning in order.

- Use a curve cutting saw to remove waste.
- Thread the plate onto the drive spindle.
- Draw the diagonals onto the wood face.
- Set up the tool rest and start turning.
- Draw a circle larger than bowl to be turned.
- Screw the piece to the faceplate.

STEP 1 _____

STEP 2 _____

STEP 3 _____

STEP 4 _____

STEP 5 _____

STEP 6 _____

- 11 For what purpose is the 'long hole boring auger' used?

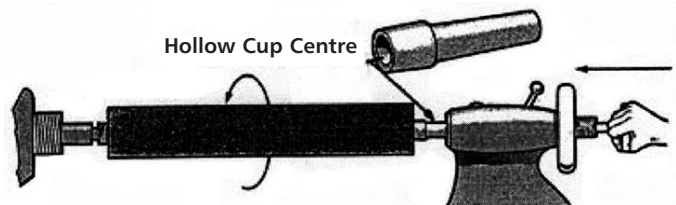

Woodturning Crossword

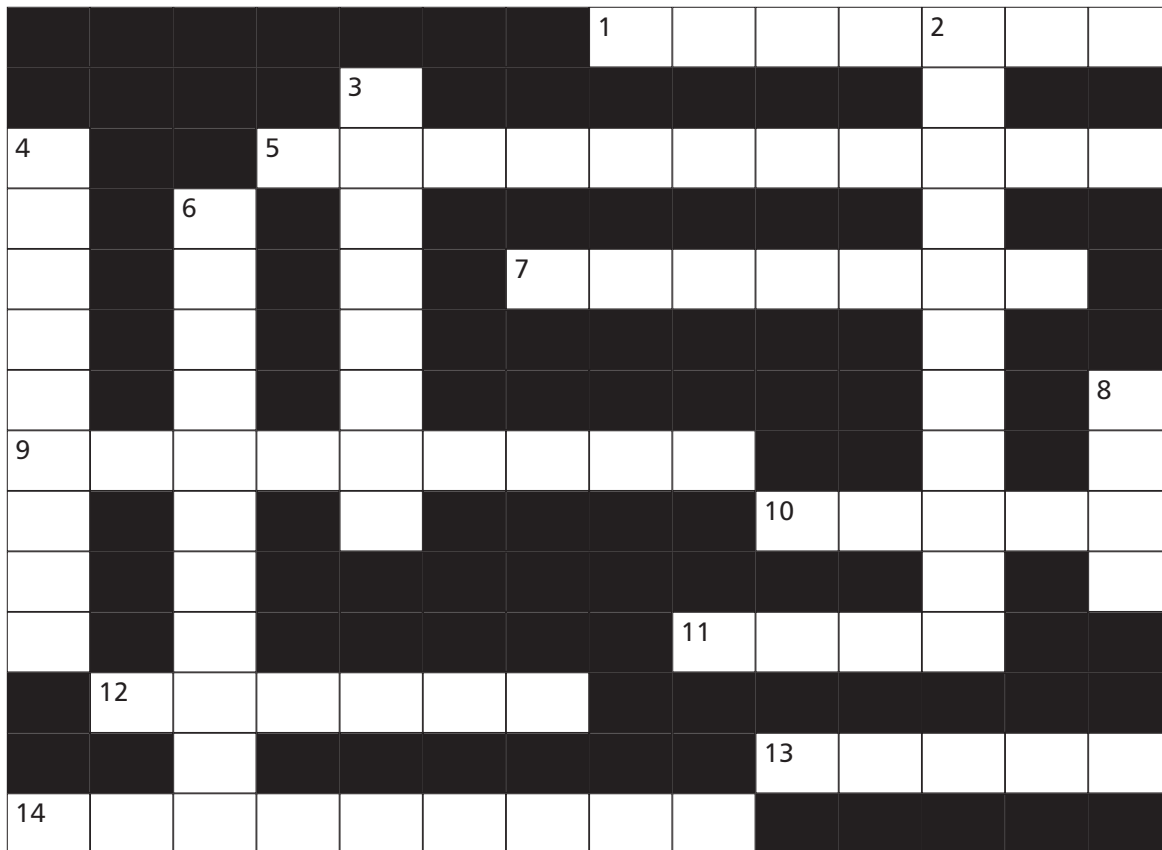

Across

- 1 Another name for between centre turning. (7)
- 5 Work done on a lathe machine. (11)
- 7 Tool used to put a smooth finish inside a bowl. (7)
- 9 Moveable end which holds a live, dead or hollow cup centre. (9)
- 10 The machine used for woodturning. (5)
- 11 A _ _ _ _ plate is used for bowl turning. (4)
- 12 Round bladed tools used for turning. (6)
- 13 This part of the lathe holds the tool rest. (5)
- 14 Inside and outside _ _ _ _ _ _ are used to check diameters. (9)

Down

- 2 This has prongs to grip and turn the piece. (5,6)
- 3 This is used for holding the tool firmly on for turning. (4,4)
- 4 The part of the lathe which houses the motor and pulleys. (9)
- 6 Used to make thin grooves in the wood the thickness of the blade. (7,4)
- 8 A _ _ _ _ chisel is used to give a fine finish to a work piece. (4)

Woodturning Wordsearch

W	O	O	D	T	U	R	N	I	N	G	Z	X	M
Q	H	Z	X	B	F	N	M	K	Q	W	M	M	C
T	E	M	P	L	A	T	E	Q	Z	X	X	S	A
F	A	Q	K	K	C	K	Z	X	N	N	D	K	L
F	D	R	I	V	E	C	E	N	T	R	E	E	L
S	S	C	R	A	P	E	R	S	A	P	O	W	I
P	T	Z	X	Z	L	Q	K	M	I	P	O	C	P
I	O	Q	G	G	A	Z	G	K	L	A	T	H	E
N	C	S	S	S	T	X	O	K	S	P	P	I	R
D	K	B	V	V	E	V	U	G	T	V	V	S	S
L	P	A	R	T	I	N	G	T	O	O	L	E	Z
E	J	N	Z	M	M	Q	E	S	C	J	N	L	Z
R	Q	J	Z	W	W	W	S	S	K	J	M	M	X
T	O	O	L	R	E	S	T	S	M	M	M	Q	Q

Find the following keywords associated with woodturning in the grid above:

LATHE

WOODTURNING

HEADSTOCK

TAILSTOCK

TOOL REST

BANJO

FACEPLATE

GOUGES

SCRAPERS

PARTING TOOL

SPINDLE

SKEW CHISEL

CALLIPERS

TEMPLATE

DRIVE CENTRE

**Targets
5, 6 & 7**

Plastics and Metals

Keywords

Thermoplastic	Thermosetting	Moulded	P.V.C.
Acrylic	Perspex	Strip-Heater	
Polythene	Polystyrene	Polyurethane	

Plastics: There are two types:-

Thermoplastics which can be **heated** and **moulded** into various shapes and can then be **reheated** and **remoulded** into different shapes.

Thermosetting Plastics cannot be remoulded once the shape is set.

Examples of plastics and their uses:

THERMOPLASTICS	USES
Acrylic (Perspex)	A substitute for glass
Polystyrene	White insulation in cavity walls and packaging
Polythene	Plastic bags
Polyvinyl Chloride (PVC)	Water pipes and windows and doors (uPVC)
Nylon	Gearwheels, clothing, plug casings

THERMOSETTING	USES
Polyurethane	In varnish and paints
Polyester Resin	Car bodies and electrical switches and sockets

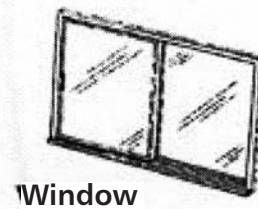
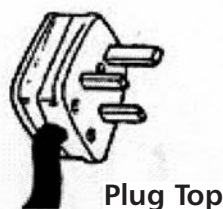
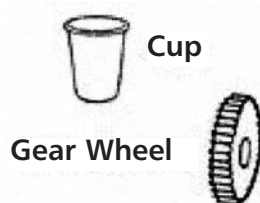

Acrylic (Perspex)

Acrylic, sold under the trade name 'Perspex' is the most common plastic used in M.T.W. projects, so it is important to know how to work with it...

To show the processes involved in this we will use the example of a simple **pencil holder** shown:

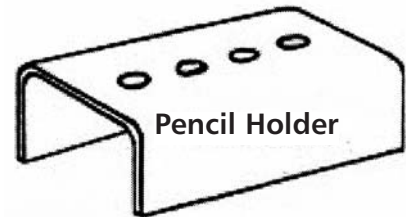

- 1 Marking out:** Acrylic is easily scratched so it is sold covered on both sides by a clear plastic film. The full piece (the development), can be marked using a pencil, marker or scribe. Before the final process of bending, this coating is removed and the fold lines can be drawn using a non-permanent marker.

Centre for drilling holes

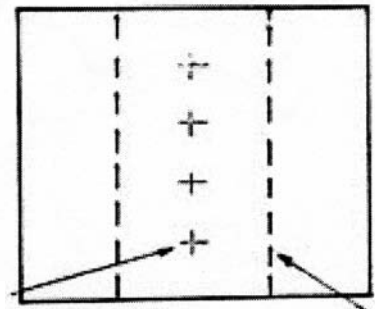

Bend Lines

- 2 Cutting:** When using a tenon saw or a hack saw to cut acrylic, you must clamp the piece tight as close as possible to the cut line (to stop the sheet vibrating), and keep the saw blade at a low angle to stop chipping. If the piece contains curves, a fret saw, scroll saw or band saw may be used to cut round them.

- 3 Drilling:** When drilling a hole in acrylic the sheet must be held firmly using a vice or cramps. A waste piece should also be used beneath it to stop the drill bit from breaking through and cracking the plastic.

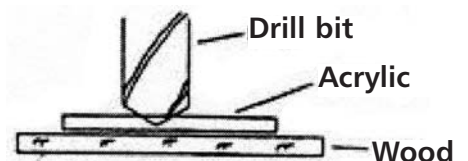

- 4 Filing and Planing:** The rough edges of the plastic must be finished with a plane or file. If planing, set the acrylic as low as possible in the vice and use a block plane set very finely and angled slightly when planing.

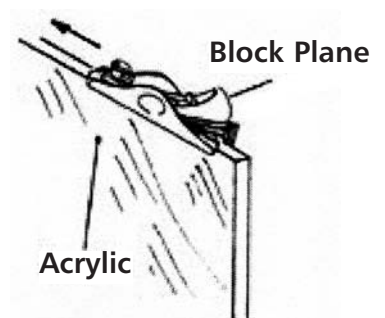

If filing, the edge can be cross-filed down to the waste line and draw-filed to smooth off the cross-filed marks.

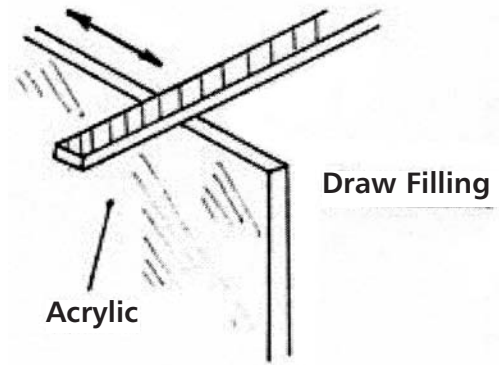
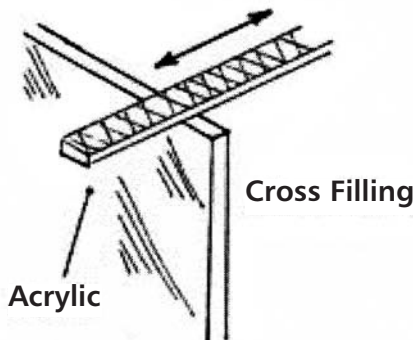

- 5 Finishing:** For the final stage of finishing, the edge can be sanded using very fine sandpaper and polished with a cloth, using 'brasso'.

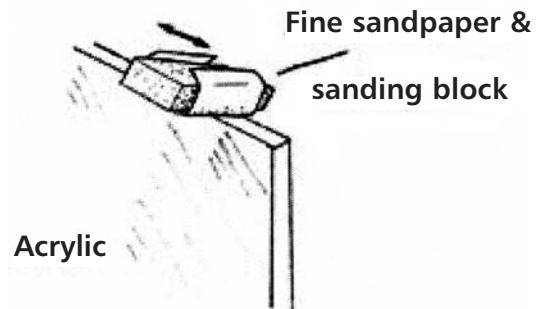

- 6 Bending:** Remove the protective layers of plastic and mark the broken lines where the bending is to be done. A 'Strip Heater' is used to soften the acrylic along the fold line by using a glowing hot element in the machine. When the plastic is soft enough it is bent to the required shape using a timber block cut to the shape of the curve required, and allowed to cool. When it cools it hardens again and keeps its new shape.

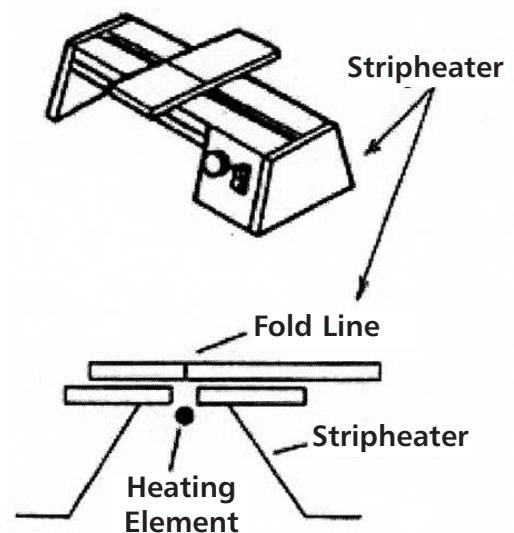
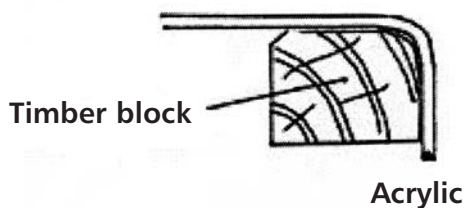

Worksheet on Plastics

- 1 Place the words **Thermoplastic** and **Thermosetting Plastic** in the table, to match the given property:

	Can be remoulded.
	Cannot be remoulded.

- 2 Place a tick (✓) opposite each plastic listed in the table below to indicate if it is a Thermoplastic or Thermosetting plastic:

The example given identifies Polystyrene as a Thermoplastic.

PLASTICS	THERMOPLASTIC	THERMOSETTING
Acrylic (Perspex)		
Polystyrene	✓	
Polyurethane		
Polythene		
Polyester Resin		
Polyvinyl Chloride(PVC)		

- 3 From the list of plastics in Q2, place each one opposite its use:

PLASTICS	USES
	Plastic bags
	A substitute for glass
	In varnish and paints
	Water pipes and windows and doors
	Car bodies and electrical switches and sockets
	White insulation in cavity walls and packaging

- 4 Place the processes from the list in the correct order; as they would be used to make the 'pencil holder' shown.

ORDER

PROCESSES

- | | |
|---------|--------------------|
| 1 _____ | Bending |
| 2 _____ | Drilling |
| 3 _____ | Finishing |
| 4 _____ | Cutting |
| 5 _____ | Filing and Planing |
| 6 _____ | Marking Out |

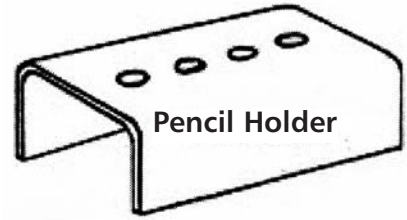

- 5 Why is Perspex sold with a protective plastic covering?

- 6 What is used to mark broken lines on Perspex before bending?

- 7 List 2 saws used to cut straight and curved lines in Perspex

(i) Straight Cutting: _____

(ii) Curved Cutting: _____

Targets 5, 6 & 7

Plastics and Metals

8 Why is the timber placed under the Perspex when drilling, as shown?

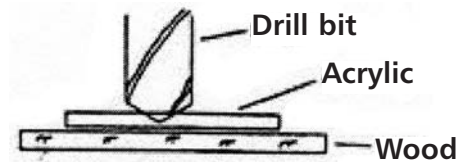

9 From the list given, select the plane most suitable for use when planing the edge of Perspex:

- (a) Try-plane. (b) Rebate-plane (c) Block-plane (d) Jack-plane.

Answer: _____



10 What are the two types of filing used to finish the edges of Perspex?

(i) C _____ Filing.

(ii) D _____ Filing.

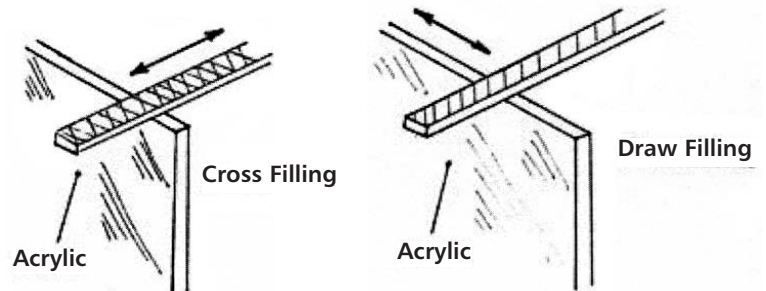

11 For the final touches to the edges of Perspex, it should be s _____

using very fine s _____ p _____ and polished with a cloth using

b _____ .

12 What is the name of the machine, shown in the diagram, used to heat Perspex and allow it to bend into shape?

Answer: S _____ H _____.

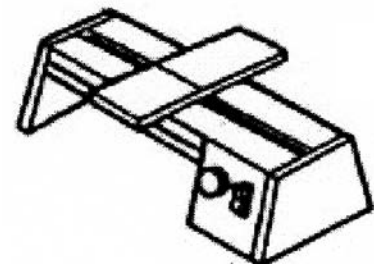

Keywords

Ferrous	Alloy	Corrosion	Rust	Zinc
Painting	Primer	Galvanising	Iron	Steel
Copper	Brass	Aluminium	Undercoat	

The two main groups of metals are: **Ferrous** (containing **Iron**) and **Non-Ferrous** (metals not containing **Iron**). Sometimes it is better to join two metals together because the properties of the mixture are useful. This mixture is called an **Alloy** e.g. Brass is a mixture of copper and zinc.

The following is a table containing some of the common metals and their uses:

FERROUS	
NAME	USES
Cast Iron	Woodwork Planes
Mild Steel	Nails and Screws
Carbon Steel	Chisels and Saws
Stainless Steel	Sinks and Cutlery

NON-FERROUS	
NAME	USES
Aluminium	Windows, Ladders and Cans
Copper	Water Pipes and Electric Wire
Zinc	In Paints and Galvanising
Lead	Roof Waterproofing

ALLOYS	
NAME	USES
Brass	Screws and Hinges
Bronze	Coins and Statues
Solder	Joining Metals

The iron present in ferrous metals is prone to **Corrosion** due to **Rust** if it is exposed to the air for a period of time. This corrosion can be prevented if the metal is properly treated. This is done by **Painting** or **Galvanising**.

Method 1. Painting using the following steps:

Step 1 Make sure the surface of the metal is clean and free from grease.

Step 2 Use sandpaper to roughen-up the surface of the metal. This will ensure a better bond for the paint.

Step 3 Brush on a 'primer' coat. This forms a strong bond with the metal and a good base for the undercoat.

Step 4 Brush on 'undercoat 1' which provides an even surface for the paint.

Step 5 When dry brush on 'undercoat 2'.

Step 6 Brush on a gloss 'finishing' coat of paint.

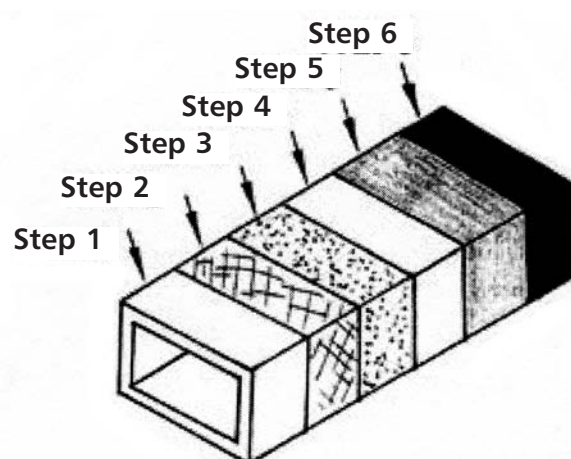

Method 2. Galvanising using the following steps:

Step 1 Make sure the surface of the metal is clean and smooth.

Step 2 The metal is dipped into a bath of molten (liquid) 'zinc'.

Step 3 Allow the coat of zinc to cool and harden. Zinc does not rust and will protect the metal.

Worksheet on Metals

1 Ferrous metals contain I _____.

Non ferrous metals do not contain I _____.

2 Which of the two groups of metals named in Q1 will rust?

Answer: _____

3 Two metals can be mixed together to form an A _____.

4 Name the two methods used to prevent metals from rusting:

(a) P _____ . (b) G _____ .

5 Method (b) from Q4 requires the bare metal to be coated in a layer of

Z _____ , to prevent rusting.

6 Put in order the steps involved in method (a) from Q4 above:

Undercoat 1, Primer, Gloss coat, Undercoat 2, Sanding, Cleaning.

Step 1 _____ Step 2 _____

Step 3 _____ Step 4 _____

Step 5 _____ Step 6 _____

Targets 5, 6 & 7

Plastics and Metals

- 7 Put the following list of metals into the table under their correct heading:
Zinc, Cast Iron, Lead, Solder, Stainless Steel, Copper, Bronze, Carbon Steel, Brass,
Aluminium, Mild Steel.

FERROUS	NON-FERROUS	ALLOY

- 8 Give one use for each of the following metals:

NAME	USE
Cast Iron	
Mild Steel	
Carbon Steel	
Stainless Steel	
Aluminium	
Copper	
Zinc	
Lead	
Brass	
Bronze	Coins and Statues
Solder	

Plastics and Metals Crossword

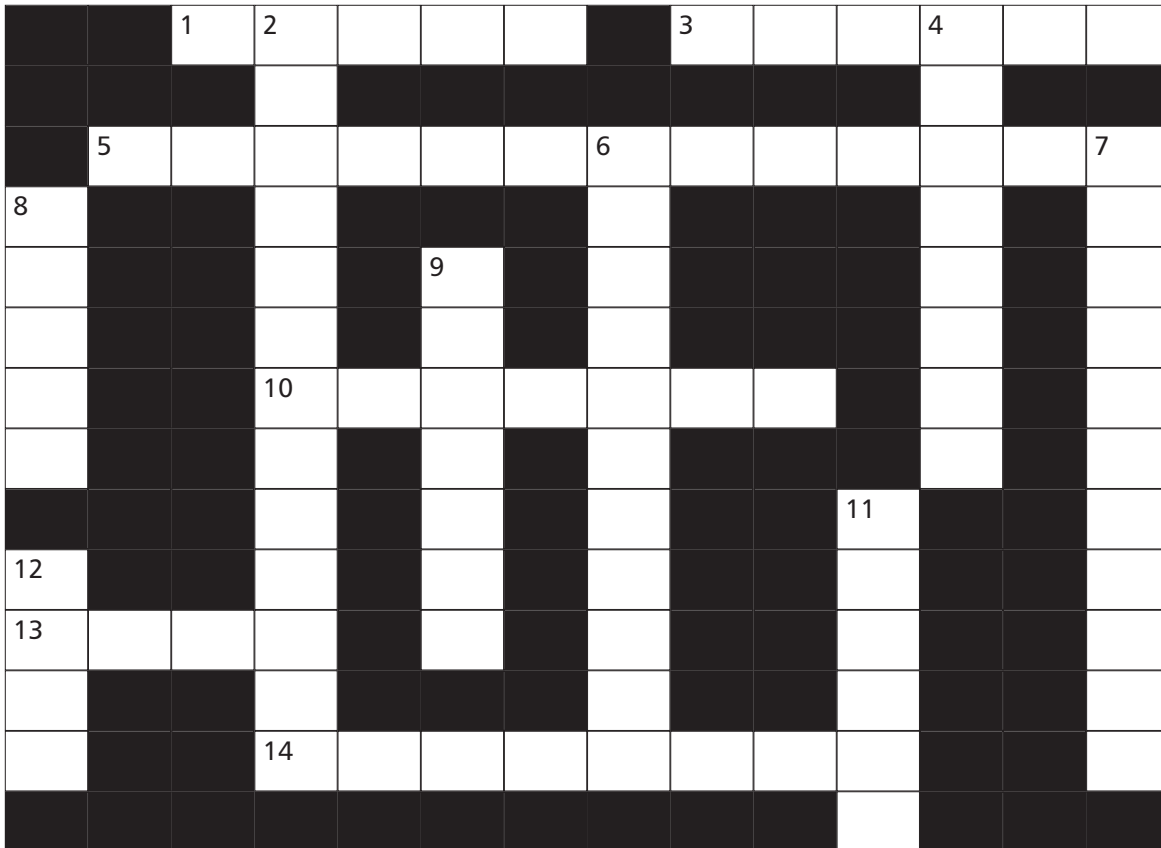

Across

- 1 Mild, Stainless and Carbon S _ _ _ _ _ are all ferrous metals. (5)
 3 This pure metal is used for electrical wires. (6)
 5 This type of plastic cannot be remoulded. (13)
 10 Acrylic, a thermoplastic, is sold under the trade name P _ _ _ _ _ . (7)
 13 Corrosion in metals is caused by R _ _ _ _ . (4)
 14 PolyVinyl C _ _ _ _ _ _ _ is a thermoplastic used for water pipes. (8)

Down

- 2 This type of plastic can be remoulded into different shapes. (13)
 4 P _ _ _ _ _ _ _ is one method of protecting ferrous metals from corrosion. (8)
 6 This machine is used to heat plastic, along a line, for bending. (5,6)
 7 Coating metal in zinc is called G _ _ _ _ _ _ _ _ _ . (11)
 8 A mixture of two metals is called an A _ _ _ _ _ . (5)
 9 F _ _ _ _ _ _ _ metals are those which contain iron. (7)
 11 In painting metals a P _ _ _ _ _ _ _ coat is used to form a good base for 'undercoat 1'. (6)
 12 This is present in ferrous metals and makes them prone to rusting. (4)

Seasoning Wordsearch

T	H	E	R	M	O	P	L	A	S	T	I	C	A
F	E	R	R	O	U	S	Z	L	X	H	Q	K	C
U	Z	Q	W	U	Z	B	X	L	Z	E	Q	Z	R
N	I	P	K	L	Q	R	C	O	Z	R	Q	Q	Y
D	N	O	K	D	Q	A	O	Y	X	M	Z	K	L
E	C	L	P	E	R	S	P	E	X	O	F	F	I
R	W	Y	P	D	W	S	P	W	W	S	Y	Y	C
C	S	T	R	I	P	H	E	A	T	E	R	Q	Q
O	S	H	I	K	V	R	R	I	X	T	X	X	X
A	S	E	M	K	C	R	R	R	S	T	E	E	L
T	S	N	E	C	O	R	R	O	S	I	O	N	L
Z	S	E	R	Q	W	W	U	N	A	N	A	A	A
G	A	L	V	A	N	I	S	I	N	G	M	N	M
Z	Z	Z	P	A	I	N	T	I	N	G	M	N	N

Find the following keywords associated with Metals and Plastics in the grid above:

THERMOPLASTIC

THERMOSETTING

MOULDED

ACRYLIC

PERSPEX

STRIP-HEATER

POLYTHENE

P.V.C.

FERROUS

ALLOY

CORROSION

RUST

BRASS

PAINTING

PRIMER

GALVANISING

UNDERCOAT

IRON

ZINC

STEEL

COPPER

**Targets
8, 9 & 10**

Woodcarving

Keywords

Carving	Chip	Incised	Relief	Mallet
Knife	Chisel	Gouges	Vee-Tool	Blank
Carbon-Paper	Low Relief	High Relief		

Carving is the cutting and shaping of wood. It can be used to make plain projects look decorative, which is a feature often looked for in design briefs.

Types of Carving

- 1 Chip Carving
- 2 Incised Carving
- 3 Relief Carving
- 4 Carving in the Round

Timber suitable for carving: When selecting a timber for use in carving, it is best to select a timber which is:

- Easy to work with.
- Have straight close grain.
- Soft.
- Suitable colour (generally softwoods are light coloured and hardwoods are darker).

Good examples are **sycamore, lime, oak, walnut, mahogany** and **pine**. The manufactured board **M.D.F.** (medium density fibreboard) is also suitable for carving because it has a soft structure with no grain, which allows carving tools to slice through the layers easily in all directions.

Tools Used for Carving

The basic tools used for carving (removing the waste) are **chisels, gouges** and **knives**. These tools should be used in the direction of the grain, as much as possible.

A **carver's chisel** has a bevel (slope) at each side of the cutting edge.



A **bevel edged chisel** is used in chip carving.

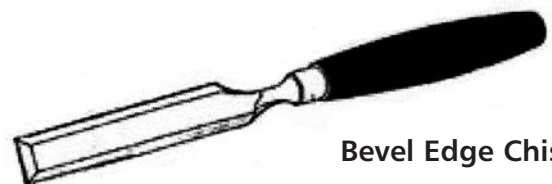

Bevel Edge Chisel

Gouges scoop out waste. They have a curved blade and are bevelled on the inside or outside depending on the carving.



Carving Gouge

A **V-tool** is used to cut a 'V' shape in the wood. It is used in chip, incised and relief carving.



V-Tool

Chip Carving

This is a simple type of carving based on a triangle repeated to form a decorative pattern. The pattern is drawn onto the wood using drawing instruments. The carving is done using a **Knife** or **Chisel**.

How to cut out the basic chip:

- 1 Draw an equilateral triangle.
- 2 Clamp the wood to the bench or in a vice.
- 3 Use a bevel edged chisel at an angle as shown and tap the chisel to a depth of about 3mm at B.
- 4 Repeat this along the line BC.
- 5 Slice out the waste as shown.

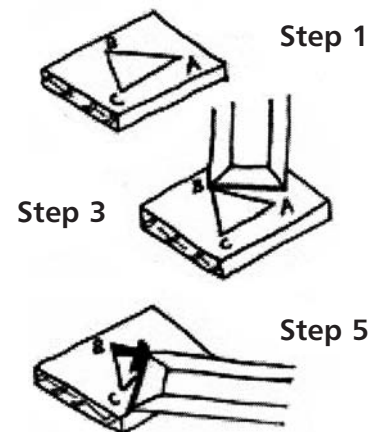

How to remove a six-cut chip:

- 1 Draw a triangle and bisect the angles to find the centre.
- 2 Use a V-tool to cut from the corners to a depth of 3mm at the centre. These are stop cuts.
- 3 Use a bevel edged chisel to slice away the waste from each of the three small triangles.
- 4 Repeat this procedure to produce designs like the ones shown below:

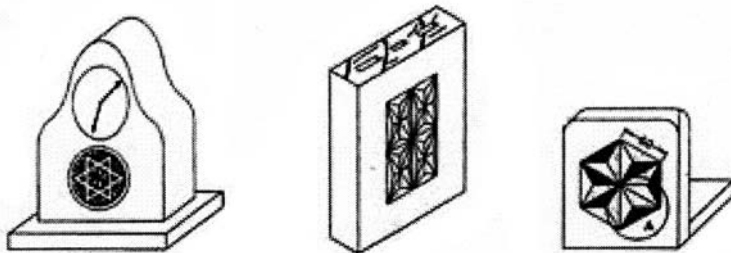
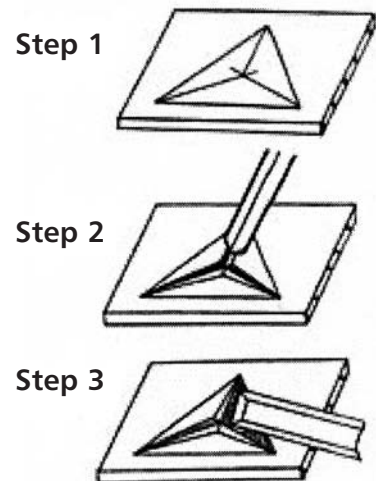

Before any of the other methods of carving can be attempted we must be able to transfer designs onto wood. This is done using carbon paper, as follows:

- 1 Position the drawing on the wood and tape one edge down.
- 2 Slip the sheet of carbon paper between the design sheet and the wood (carbon side down).
- 3 Draw over all lines of the design. Make sure all lines are transferred before removing the carbon paper and design.

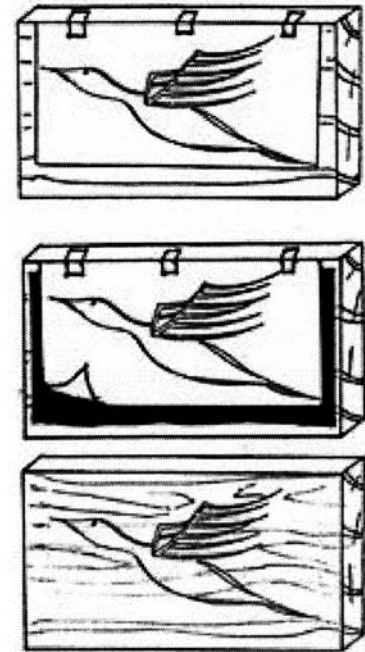

Incised Carving

This is where the outline of a design is cut using a V-tool (veiner).

- 1 Transfer the design to the wood as shown above.
- 2 Use the V-tool in the direction of the grain along the outline of the design.
- 3 Try to keep the depth and width of the cut even for best effect.
- 4 Sand smooth when finished.

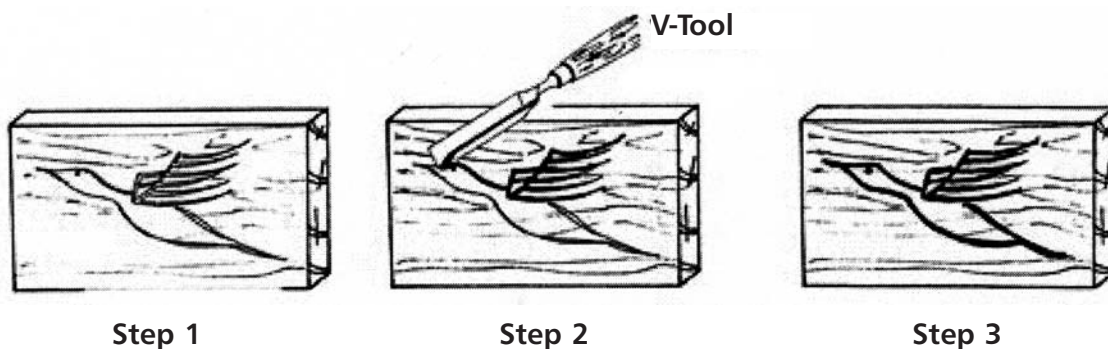

Relief Carving

With this method the wood around the design is removed leaving it to stand out. A shallow cut of waste is called **Low Relief**, while a deep cut is called **High Relief** (over 10mm).

- 1 Transfer the design onto the wood as before.
- 2 Clamp the wood down.
- 3 Cut around just outside the design to a depth of 3mm with a V-tool. This is called **Outlining**.
- 4 Remove the background waste with a wide gouge. This is called **Grounding**.
- 5 Trim the design back to its outline using vertical paring.
- 6 The edge of the design can then be rounded using a gouge.
- 7 The background can be textured using a serrated punch.

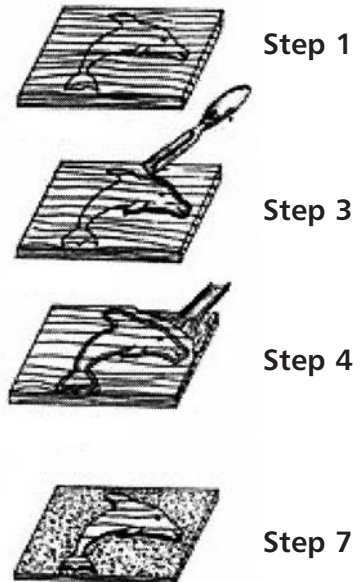

Carving in the round

This is sometimes known as 3-D carving. It starts with a basic block called a **Blank**. For simple shapes a front and side view of the object to be carved are needed.

- 1 Transfer the views onto the blank using carbon paper.
- 2 Cut out around the outline using a band saw.
- 3 Replace the cut waste and cut around the other view.
- 4 Fix the piece and shape it further using various gouges and a carver's mallet. Work in the direction of the grain.

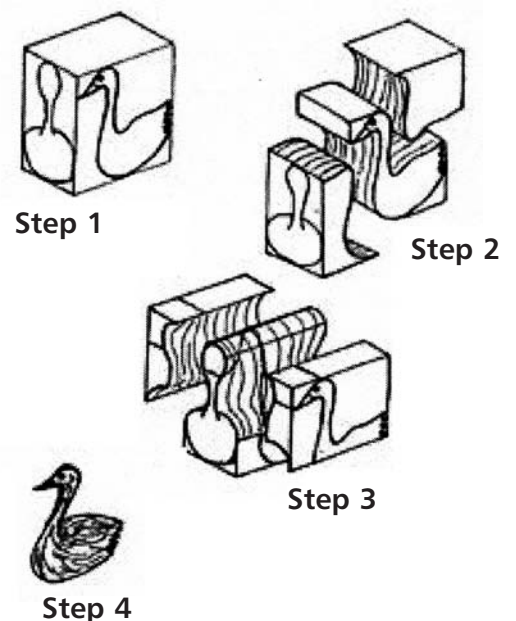

Carvers mallet



Step 4

Questions on Woodcarving

1 Name the following tools used in woodcarving.



2 Complete the following list of some types of carving.

C _____ Carving.

I _____ Carving.

R _____ Carving.

3 Name three timbers suitable for carving.

(i) _____ (ii) _____ (iii) _____

4 Why is the manufactured board **M.D.F.** suitable for carving?

5 Name the methods of carving shown in the diagrams.

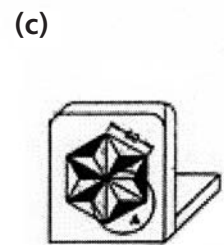
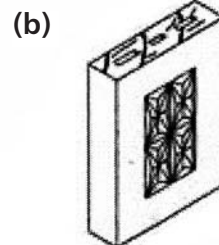
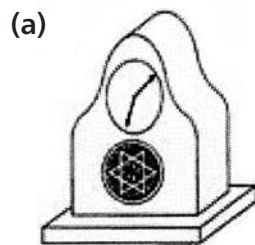

Method (a): _____

Method (b): _____

Method (c): _____

6 Describe the steps involved in transferring a design to wood.

Step 1 _____

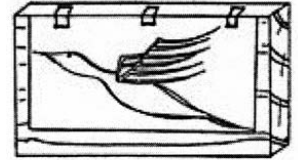

Step 2 _____



Step 3 _____



7 Describe how to cut a basic chip as shown.

Step 1 _____

Step 2 _____

Step 3 _____

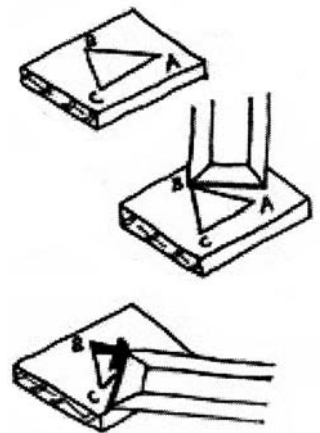

Targets 8, 9 & 10

Woodcarving

8 Describe how the following carving is done.

Step 1 _____

Step 3 _____

Step 4 _____

Step 7 _____



Step 1



Step 3



Step 4



Step 7

9 List the steps involved in the carving shown.

Step 1 _____

Step 2 _____

Step 3 _____



Step 1

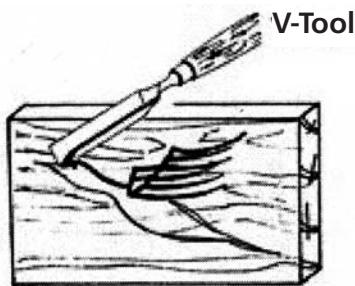

Step 2



Step 3

Woodcarving Crossword

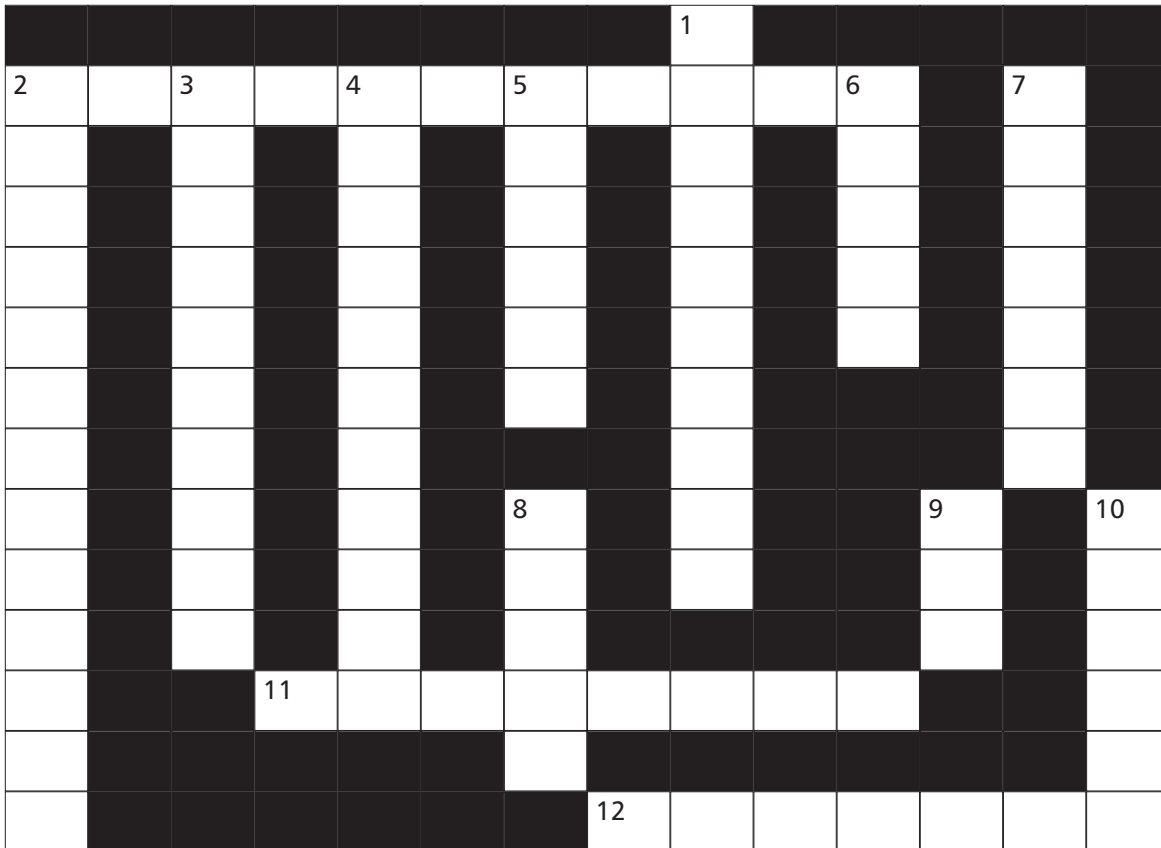

Across

- 2 Carving based on a pattern of triangles. (4,7)
- 11 Before carving you may need to _____ a design onto the wood. (8)
- 12 Tool used to cut around the outline of a design for Incised Carving. (3,4)

Down

- 1 Type of relief carving involving the removal of deep waste. (4,6)
- 2 Tool with a round head used to strike carving chisels. (7,6)
- 3 Carving _____ is also known as 3D carving. (2,3,5)
- 4 This is used to transfer a design onto wood. (6,5)
- 5 R _____ carving is based on the removal of the background. (6)
- 6 Curved blade chisels used for carving. (6)
- 7 Carving based on outlining the design using a Vee-tool. (7)
- 8 The name for a starting block used for carving in the round. (5)
- 9 _____ relief is the name given to a Relief carving with shallow waste. (3)
- 10 A bevel edged _____ is used to remove a simple chip. (6)

Woodcarving Wordsearch

C	A	R	V	E	R	S	M	A	L	L	E	T	Q
H	Q	L	W	E	R	T	Y	U	I	O	V	P	P
I	Z	O	N	G	O	U	G	E	Q	Z	E	X	P
P	X	W	T	R	A	N	S	F	E	R	E	C	S
C	A	R	B	O	N	P	A	P	E	R	T	V	I
A	C	E	B	U	Q	P	Z	R	W	E	O	O	X
R	B	L	A	N	K	O	X	T	E	L	O	U	C
V	V	I	V	D	W	I	X	E	R	I	L	T	U
I	B	E	C	I	E	C	H	I	S	E	L	L	T
N	N	F	X	N	R	U	C	E	T	F	Z	I	C
G	N	Z	X	G	T	Y	V	W	Y	P	X	N	H
M	H	I	G	H	R	E	L	I	E	F	V	I	I
I	N	C	I	S	E	D	B	Q	U	O	B	N	P
I	N	T	H	E	R	O	U	N	D	I	M	G	O

Find the following list of keywords associated with woodcarving in the grid above:

CHIP CARVING	INCISED	RELIEF	IN THE ROUND
CARVERS-MALLET	SIX-CUT-CHIP	CHISEL	VEE-TOOL
CARBON-PAPER	HIGH-RELIEF	LOW-RELIEF	TRANSFER
GROUNDING	BLANK	GOUGE	OUTLINING

